



**THE EXHIBITORS'  
HAND  
BOOK**  
**MODULAR DISPLAY SOLUTIONS**

**BANNER STANDS | RETRACTABLE**..... 1-6

**BANNER STANDS | TELESCOPIC**..... 7-8

**BANNER STANDS | SPRING BACK**..... 9-11

**OUTDOOR PRODUCTS**..... 12-15

**BACKWALLS & INFO CENTERS** ..... 16

**VECTOR FRAME | TENSION FABRIC WALLS & EXHIBITS**... 17-19

**HOPUP | TENSION FABRIC DISPLAY SYSTEMS**..... 20-21

**POPOP DISPLAY SYSTEMS | CASES**..... 22-26

**FORMULATE | TENSION FABRIC EXHIBITS**..... 27-30

**FORMULATE | FABRIC HANGING STRUCTURES** ..... 31-33

**VIBE | TENSION FABRIC EXHIBITS**..... 34-35

**TABLE THROWS AND RUNNERS** ..... 36-37

**FOLDING DISPLAY PANELS**..... 38-41

**ORBITAL EXPRESS TRUSS** ..... 42-58

**LINEAR DISPLAY SYSTEMS**..... 59-63

**KIOSKS**..... 64-65

**COUNTERS**..... 66-67

**DISPLAY ADDITIONS**..... 68

**LITERATURE RACKS** ..... 69

**CASES & CRATES** ..... 70-71

**LUMINOSITY | DISPLAY LIGHTING** ..... 72

**SYMBOLS USED IN THE EXHIBITORS' HANDBOOK:**



premium product



product can be recycled  
(does not include graphic application)



product made in the U.S.



standard product



new addition to  
The Exhibitors' Handbook



economy product



product comes with  
a carry bag or case

**WARRANTY KEY:**



lifetime warranty  
(hardware)



90 day warranty  
(hardware)



5 year warranty  
(hardware)



graphics limited  
1 year warranty  
(indoor products)



1 year warranty  
(hardware)



graphics limited  
6 month warranty  
(outdoor and table  
throw products)



### BLADE LITE

23.5" WIDE BLD-LT-600

36" WIDE BLD-LT-920

47.25" WIDE BLD-LT-1200

59" WIDE BLD-LT-1500

- four widths to choose from: 23.5", 36", 47.25", 59"
- premium top rail
- weighted base for stability
- adjustable leveling feet
- 3-piece bungee pole







# PREMIUM RETRACTABLE BANNER STANDS



Premium Retractable banner stands provide superior, high-end functionality, features and durability, as well as unique styling points for exceptional appearance. Premium banners include a protective, molded carry bag and feature a lifetime hardware warranty.



## IMAGINE

**31.5" WIDE** IMG-800-S

- variable height = 29.5" - 83.35"
- graphic tensioner
- integrated pole storage
- interchangeable graphic cassette
- adjustable feet on base
- telescopic pole

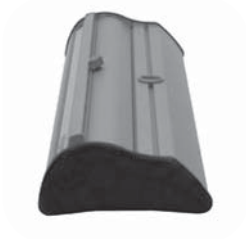

## BARRACUDA

**31.5" WIDE** BCD-800-S  
BCD-800-B

- variable height = 29.5" - 83.35"
- graphic tensioner
- integrated pole storage
- anodized silver or black
- adjustable feet on base
- telescopic pole



## ADVANCE

**31.5" WIDE** ADV-800-S

- variable height = 29.5" - 83.35"
- double sided
- graphic tensioner
- integrated pole storage
- interchangeable graphic cassette
- adjustable feet on base
- telescopic pole

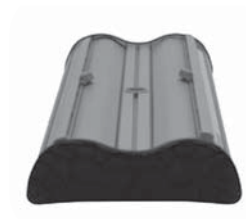

## EXCALIBUR

**31.5" WIDE** EXC-800-S  
EXC-800-B

- variable height = 29.5" - 83.35"
- double sided
- graphic tensioner
- integrated pole storage
- adjustable feet on base
- telescopic pole

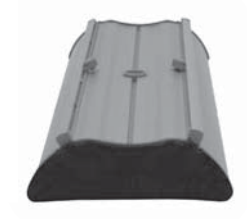



# STANDARD RETRACTABLE BANNER STANDS

Standard Retractable banner stands incorporate customary features designed to provide everyday reliability, durability and ease of use. Standard banners include a mid-range canvas carry bag and typically feature a five-year to lifetime hardware warranty.



## ORIENT

**31.5" WIDE** silver: ONT-800-S-3  
black: ONT-800-B-3

**35.5" WIDE** silver: ONT-920-S-3  
black: ONT-920-B-3

**39.25" WIDE** silver: ONT-1000-S-3  
black: ONT-1000-B-3

- standard height = 85.04"
- anodized silver or black
- molded end caps
- adjustable feet on base
- 3-piece bungee pole



## ORIENT 2

**31.5" WIDE** silver: ONT-800-DBL-S-3  
black: ONT-800-DBL-B-3

**35.5" WIDE** silver: ONT-920-DBL-S-3  
black: ONT-920-DBL-B-3

**39.25" WIDE** silver: ONT-1000-DBL-S-3  
black: ONT-1000-DBL-B-3

- standard height = 85.04"
- double-sided
- anodized silver or black
- molded end caps
- adjustable feet on base
- 3-piece bungee pole



## PACIFIC

**31.5" WIDE** PAC-800-S-2

**35.5" WIDE** PAC-920-S-2

**39.25" WIDE** PAC-1000-S-2

- standard height = 83.75"
- anodized silver
- molded end caps
- swivel-out foot
- 3-piece bungee pole



## CONTENDER

**23.5" WIDE** silver: CN-24-S  
black: CN-24-B

**29.5" WIDE** silver: CN-30-S  
black: CN-30-B

**35.5" WIDE** silver: CN-36-S  
black: CN-36-B

**47.5" WIDE** black: CN-48-B

- standard height = 77.5"
- swivel-out foot
- silver or black finish
- laser cut steel ends & swaged pole



# STANDARD RETRACTABLE BANNER STANDS



Standard Retractable banner stands incorporate customary features designed to provide everyday reliability, durability and ease of use. Standard banners include a mid-range canvas carry bag and typically feature a five-year to lifetime hardware warranty.

BANNER STANDS | RETRACTABLE

STANDARD



## ELEVATE

33.5" WIDE ELEVATE

- over 8' tall
- variable height = 33.25" – 96"
- roller access via flip-top lid and removable self-locking graphic roller mechanism
- black aluminum body with chrome end caps
- telescopic pole (4 segments)



## BLADE LX

33.5" WIDE BLD-LX-GRY

- standard height = 83.25"
- anodized gunmetal finish
- removable self-locking graphic roller mechanism
- graphic slider
- adjustable feet on base
- premium top rail
- 3-piece bungee pole



## ORCHID

33.5" WIDE ORCHID

- standard height = 76.75"
- quick to assemble and easy to use
- bamboo base, rail and pole are a sustainable & eco-friendly choice
- slide graphic rail
- 3-piece pole



## BLOK

33.5" WIDE BLOK-850

- standard height = 79.25"
- black base with chrome end caps
- 3-piece bungee pole



NEW



90 DAY

# ECONOMY RETRACTABLE BANNER STANDS

Economy Retractable banner stands incorporate basic design features, functionality and reliability. Economy banners include a basic carry bag and feature a 90-day hardware warranty.



## START

31.5" WIDE STRT-800

- standard height = 83.125" h
- snap top graphic rail
- swivel foot
- anodized silver finish
- 3-piece bungee pole



## FREEDOM

31.5" WIDE FRDM-800

39.25" WIDE FRDM-1000

- standard height = 82.75" h
- snap top graphic rail
- 3-piece bungee pole



MSQT-1500



MSQT-1200



MSQT-800

## MOSQUITO

31.5" WIDE MSQT-800

47.25" WIDE MSQT-1200

59" WIDE MSQT-1500

- standard height = 82.87" h
- anodized silver
- swivel-out foot
- snap top graphic rail
- 3-piece bungee pole



# ECONOMY RETRACTABLE BANNER STANDS

Economy Retractable banner stands incorporate basic design features, functionality and reliability. Economy banners include a basic carry bag and feature a 90-day hardware warranty.



## RETRACTOR 4

32.75" WIDE RTRC-4

- standard height = 78.25"
- double sided
- snap top graphic rail
- 3-piece bungee pole



## RETRACTOR 5

36" WIDE RTRC-5

- standard height = 79.375"
- velcro graphic application
- snap top graphic rail
- 3-piece bungee pole



## QUICK WALL

QWK

- standard height = 78.5"
- unit width: 32"
- graphic width: 31.5"
- kit includes 3 Mosquito 800 banner stands and 1 OCB banner stand case
- snap top graphic rail







## STANDARD TELESCOPIC BANNER STANDS

Standard Telescopic banner stands incorporate customary features designed to provide everyday reliability, durability and ease of use. Standard banners include a mid-range canvas carry bag and typically feature a five-year hardware warranty.

### PEGASUS MINI

27.5" - 48" WIDE  
silver: PGSUS-MIN-S  
black: PGSUS-MIN-B

### PEGASUS

52.5" - 95" WIDE  
silver: PGSUS-S  
black: PGSUS-B

- single or double-sided graphics
- allows for custom size graphics
- easy to store
- steel feet for stability
- telescopic pole for adjustable graphic width and height



Pegasus Mini

Pegasus



### DASH 1 & 2

31.5" WIDE  
single sided: DSH-M-1  
double sided: DSH-M-2

- variable height = 31.5" - 78.5"
- stable, anodized aluminum
- quick & easy to erect



### DASH MEGA 1 & 2

36" WIDE  
single sided: DSH-ME  
double sided: DSH-ME-2

- variable height = 36" - 93.5"
- stable, anodized aluminum
- quick & easy to erect



# STANDARD TELESCOPIC BANNER STANDS



Standard Telescopic banner stands incorporate customary features designed to provide everyday reliability, durability and ease of use. Standard banners include a mid-range canvas carry bag and typically feature a five-year hardware warranty.



## DASH LITERATURE POCKET

**31.5" WIDE** DSH-M-LR

- recommended graphic height = 44"
- 3 pocket literature dispenser option to attach to a Dash unit



## UNO

**31.5" WIDE** UN-1-ST

**36" WIDE** UN-1-MG

**48" WIDE** UN-1-MO

- variable height = 35" - 85.5"
- powder coated black weighted base



## TELESCOPIC 1

**23.5" WIDE** TEL-1-A

- variable height = 36" - 70"
- single or double sided



## TELESCOPIC 4

**31" WIDE** TEL-4

- variable height = 31" - 77"
- telescopic pole





## STANDARD SPRING BACK BANNER STANDS

Standard Spring Back banner stands incorporate customary features designed to provide everyday reliability, durability and ease of use. Standard banners include a mid-range canvas carry bag and typically feature a one-year hardware warranty.



### LIGHTNING

31" WIDE LTNG

- standard height = 77"
- snap-lock graphic rails
- 3-piece bungee pole

# ECONOMY SPRING BACK BANNER STANDS



Economy Spring Back banner stands incorporate basic design features, functionality and reliability. Economy banners include a basic carry bag and feature a 90-day hardware warranty.



## SPRING 1-1

24"  
WIDE SB-1-1

- height = 59" or 78.5"



## SPRING 1-2

27"  
WIDE SB-1-2

- height = 59" or 78.5"



## SPRING 1-3

35.25"  
WIDE SB-1-3

- height = 59" or 78.5"



## SPRING 3

27.5"  
WIDE SB-3

- standard height = 70.75"  
- #3 grommets in corners  
- single or double sided





## ECONOMY SPRING BACK BANNER STANDS

Economy Spring Back banner stands incorporate basic design features, functionality and reliability. Economy banners include a basic carry bag and feature a 90-day hardware warranty.



### SPRING 4

27" WIDE SB-4

- standard height = 60"
- #3 grommets in corners



### SPRING 6

24.5" WIDE SB-6

- standard height = 63"
- #3 grommets in corners



### SPRING 7

29.5" WIDE SB-7

- variable height = 61.5" - 69"
- #3 grommets in corners



### SCROLLER 1

28.75" WIDE SC-1

- variable height = 48" - 72"
- top scrolling mechanism allows for a variety of lengths and styles
- utilizes standard 110v power

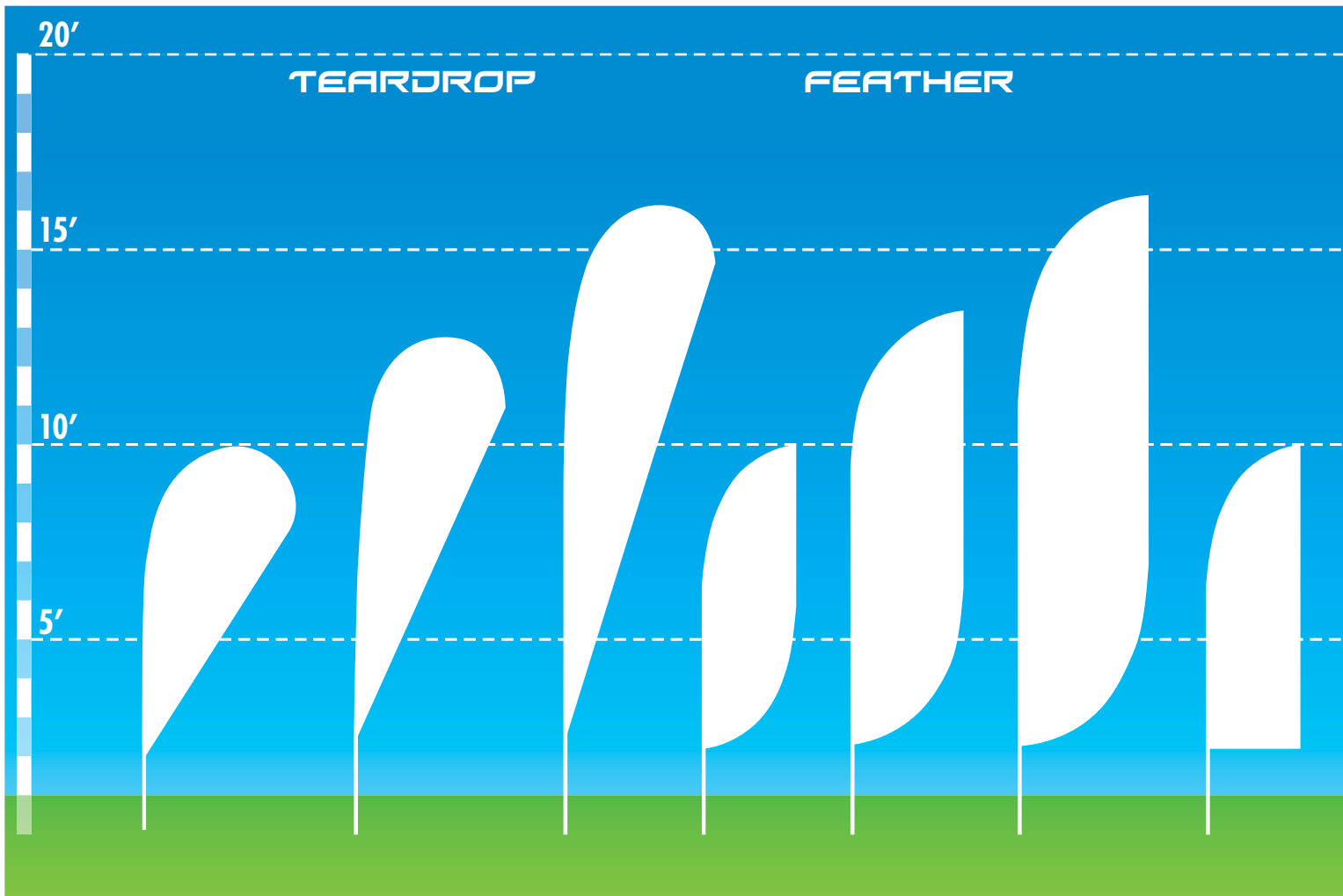

### ZOOM LINE

- can be used indoors or out
- graphic rotates in wind
- water fillable donut adds stability to quad leg (included)
- graphic printed on flag material
- double sided graphic available
- both floor base & ground stake included



shown with quad leg and water fillable donut

### WIND DANCER LT

31.5" WIDE WIND-LT

- adjustable height = up to 13'6"
- hollow base can be filled with either water or sand as weighing agent



Wind Dancer Lanyard allows a standard Wind Dancer or Wind Dancer LT to be converted into a flagpole.  
WND-MX-FPCK



All Outdoor products have a one year hardware warranty and are eco-friendly.

STRAIGHT

WIND DANCER

BLAST

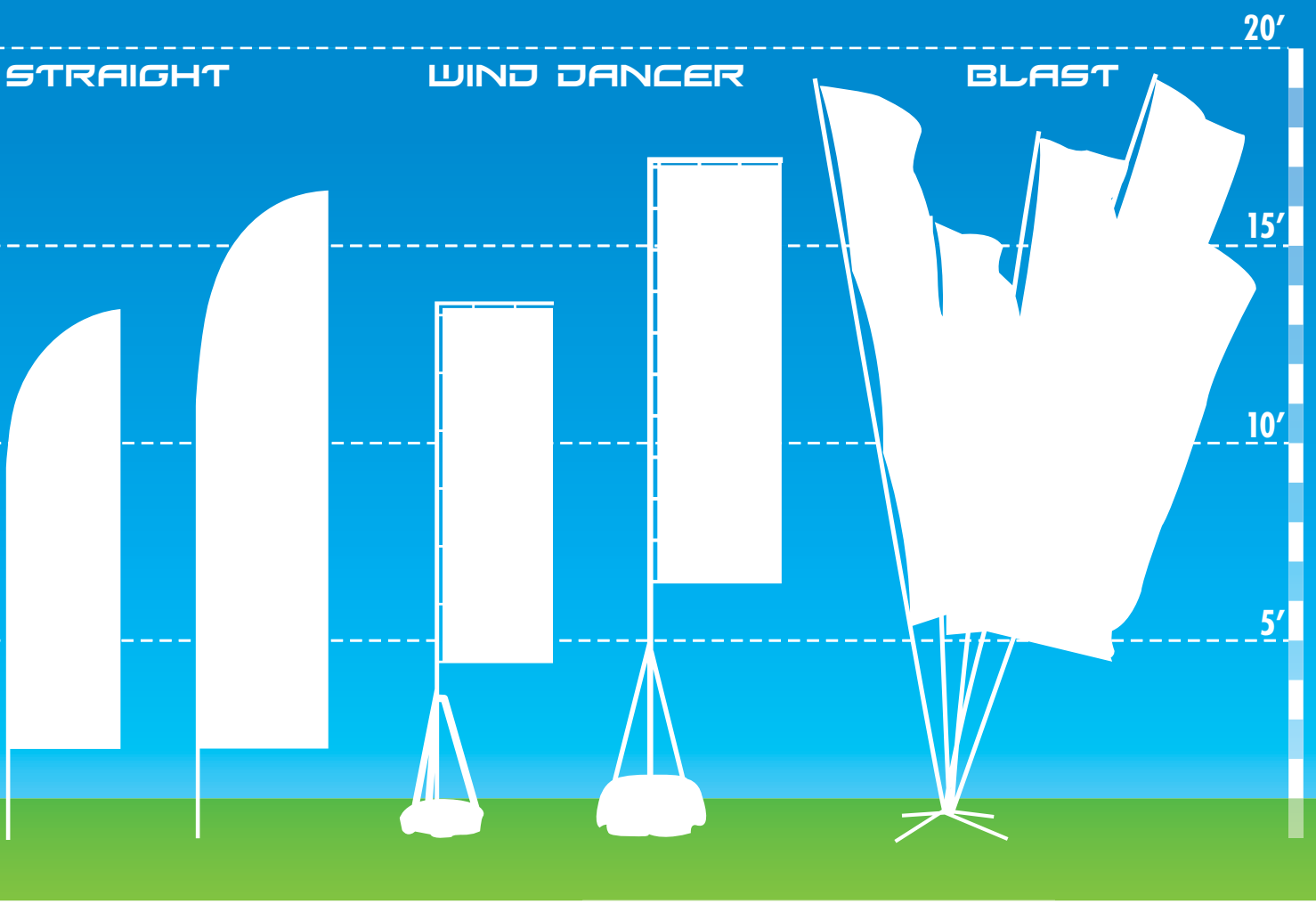

WIND DANCER

43" WIDE WIND-MX

- adjustable height = up to 17'3"
- flag is approximately 43" wide
- hollow base can be filled with either water or sand as weighing agent



Wind Dancer Spire allows a standard Wind Dancer or Wind Dancer LT to be converted into a double-sided "V" shape banner, not intended for outdoor use. WND-MX-FPCK2

BLAST

- approx. 19'8" high
- display a single flag or as many as 5
- bungee cord poles fabricated from hybrid aluminum/steel
- powder coated steel base
- comes with 4 ground spikes & rubber mallet



All Outdoor products have a one year hardware warranty and are eco-friendly.

**SPINNAKER**

8'7" TALL SPKR

- maximum graphic area of 8'w x 8'h (weather & wind conditions permitting)
- portable outdoor billboard
- single or double sided



**MONSOON**

MONSN-2



- visual area = approx. 92" w x 33" h
- semi-portable single or double sided billboard
- includes ground stakes & bungee rope



**SPRING 5**



31.5" WIDE SB-5

- standard height = 70.75"
- indoor or outdoor use
- single or double sided
- base can be filled with water or sand
- easy grommet graphic attachment
- tension pole system



**BLIZZARD**

BLZD



- max width x min height: 40" w x 49.5" h
- min width x max height: 23.5" w x 80" h
- max width x max height: 40" w x 74.5" h
- min width x min height: 23.5" w x 49.5" h
- outdoor bannerstand
- base can be filled with water or sand
- easy grommet graphic attachment



All Outdoor products have a one year hardware warranty and are eco-friendly.



## PARKWAY

single span: PKWY-S-SPN  
 double span: PKWY-D-SPN

- single sided = 32"l x 60"h
- double sided = 67"l x 60"h
- withstands winds up to 38MPH
- single or double span street pole banner



## ROCKET

- graphic area = 24"w x 36"h
- 3 legs can be filled with water or sand
- single or double sided
- spring-loaded graphic support
- 1/8" coroplast plastic or similar substrate recommended
- ideal for contour cut custom graphics
- graphic size may vary

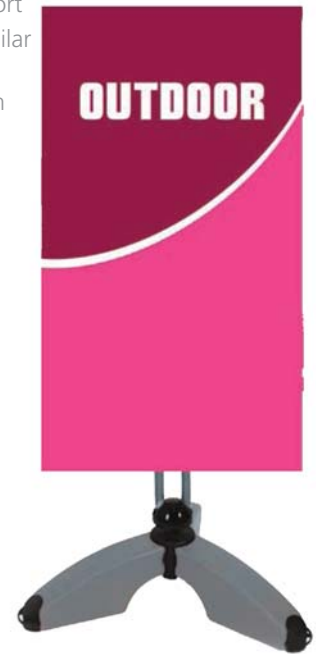

## BRUTE

- use one to hold a smaller graphic, or as many as you need to hold a large graphic
- secure grip allows for use outdoors in the elements as well as inside
- quick set-up, easy storage
- fill with water or sand, 100% emptied after use
- works with a variety of graphic substrates



contoured base sits stable on uneven terrain

recommended width:  
 1 Brute per 4' of signage

## WHIRLWIND

- 31.1"w x 45.7"h x 19.7"d
- front-loading snap frames constructed from aluminum & powder-coated steel
- single or double sided
- includes clear lens cover
- dual-spring design flexes to withstand wind gusts
- compact durable base can be filled with water or sand for extra stability
- integrated wheel set



All Outdoor products have a one year hardware warranty and are eco-friendly.

**AERO**



- indoor modular display system
- adjustable heights & angles
- shown with optional Lumina 200 floodlights
- available "à la carte" to create more combinations

**Aero Basic Kit:**

AERO-1200-BASIC

- comes with 3 1200mm cassettes and 4 uprights with base

**Aero Complete Kit:**

AERO-1200-KIT

- comes with 3 1200mm cassettes in an OCH2 case and 2 120 watt lights, no graphics (must ship freight)



complete kit comes as shown above



shown with additional panels and lights



**OBSERVE GRAND**  
OBG-B

- sleek info center includes sturdy base & adjustable shelf
- accepts 22" w x 28" h graphic size
- single or double sided
- holds a 3/16" thick mounted graphic



**OBSERVE PRO**  
OBS-LP-SYS

- lightweight snap together info center
- 12" diameter base
- stylish curved header
- adjustable brochure holder
- accepts 8.5" w x 11" h graphic and literature
- molded sign clamp will hold an 1/8" thick mounted graphic



# VECTOR FRAMES

- easy to set up and break down
- clean, simple, sophisticated look
- vibrant tension fabric graphic
- extrusion based
- single or double sided
- heavy duty silver frame & feet
- custom sizes available



## AVAILABLE SIZES:



01 Rectangle  
VF-R-01  
35" w x 47" h  
comes in 1 OCL case



02 Rectangle  
VF-R-02  
35" w x 70" h  
comes in 1 OCS case



03 Rectangle  
VF-R-03  
47" w x 70" h  
comes in 1 OCL case



04 Rectangle  
VF-R-04  
47" w x 94" h  
comes in 1 OCL case



01 Square  
VF-S-01  
35" w x 35" h  
comes in 1 OCS case



02 Square  
VF-S-02  
47" w x 47" h  
comes in 1 OCL case



03 Square  
VF-S-03  
70" w x 70" h  
comes in 1 OCS case



04 Square  
VF-S-04  
94" w x 94" h  
comes in 1 OCL case



## VECTOR FRAME WALL BRACKET

VF-BRKT-4

- supports any size vector frame
- quick and easy to assemble
- turns your vector frame from a portable to a wall display
- customer to provide fasteners
- sold in packs of four



OCS

OCL

# VECTOR FRAME KITS



counter tops are available in your choice of finishes



Stand apart from the competition with a clean, sophisticated 10'x10' or 10'x20' Vector Frame exhibit kit. The Vector Frame series is a collection of extrusion-based, dye-sublimated fabric mural graphic displays. Vector Frame exhibits are easy to assemble and disassemble.

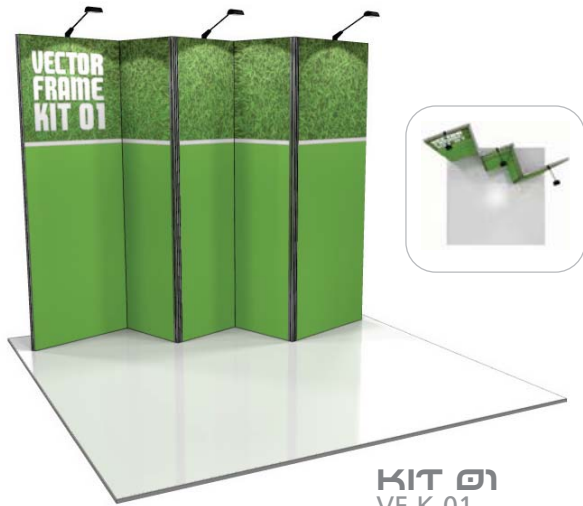

**KIT 01**  
VF-K-01



**KIT 02**  
VF-K-02



**KIT 03**  
VF-K-03

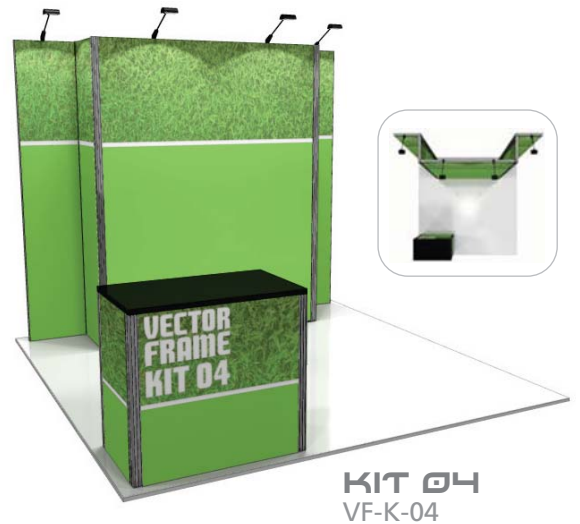

**KIT 04**  
VF-K-04



**VECTOR FRAME COUNTER**

VFC-01

- 39.375" w x 36.625" h x 22.5" d
- four locking Vector Frames
- fabric graphics for four sides
- tops available in four finishes
- comes in 1 OCH2 case



**OCH2**  
wheeled molded cases included with each kit

# HOPUP BACKWALLS

Hopup tension fabric displays are simple, versatile and can be set up in seconds. Hopups feature a lightweight, heavy-duty frame that holds a durable, stretch fabric graphic mural. Simply attach the graphic, pop (expand) the frame and you have an exhibit. All curved and straight Hopups are available with and without end caps.



## BACKLIT HOPUP **NEW**

- lightweight, heavy duty silver frame
- supports an integrated full fitted fabric graphic mural with end caps only
- available in 3x3 or 4x3 sizes (curved only)
- LED lights include one year limited warranty
- comes in an OCP molded case



interior lights are attached with velcro to back fabric panel



## HOPUP COUNTER HOP-CT-S

- collapsible display counter
- includes black internal shelf
- hinged top available in all four laminate finishes

## STRAIGHT HOPUP CONFIGURATIONS



HOP-1X1-S  
approximate frame dimensions:  
31" w x 31" h



HOP-2X1-S  
approximate frame dimensions:  
60.06" w x 31" h



HOP-2X2-S  
approximate frame dimensions:  
60.06" w x 60.06" h



HOP-3X2-S  
approximate frame dimensions:  
89.13" w x 60.06" h



HOP-1X3-S  
approximate frame dimensions:  
31" w x 89.13" h



HOP-2X3-S  
approximate frame dimensions:  
60.06" w x 89.13" h



HOP-3X3-S  
approximate frame dimensions:  
89.13" w x 89.13" h



HOP-4X3-S  
approximate frame dimensions:  
118.19" w x 89.13" h

## CURVED HOPUP CONFIGURATIONS



HOP-2X1-C  
approximate frame dimensions:  
60.06" w x 31" h



HOP-2X2-C  
approximate frame dimensions:  
60.06" w x 60.06" h



HOP-3X2-C  
approximate frame dimensions:  
89.13" w x 60.13" h



HOP-2X3-C  
approximate frame dimensions:  
60.06" w x 89.13" h



HOP-3X3-C  
approximate frame dimensions:  
89.13" w x 89.13" h



HOP-4X3-C  
approximate frame dimensions:  
118.19" w x 89.13" h

# COYOTE POPUP



Fully magnetic popup display system provides a graphic or velcro receptive fabric backwall. Available in a wide range of size configurations. (see page 24)

POPUP DISPLAY SYSTEMS







**OCP**  
OCP

- blow molded transit case
- built in wheels, handle
- light storage in the lid
- secure reinforced straps



**CASE TO COUNTER CONVERSION**

Roll Wrap: OCP-C2C-G

- available in fabric or graphic
- converts OCP to a counter
- polymer counter surface exposed



Stretch Wrap: OCP-SW-G

- stretch fabric pullover
- converts OCP to a counter
- polymer counter surface covered by fabric



**OCP ELITE**  
OCP-ELITE

- heavy duty shipping and storage case
- lid can be used as a step stool
- access door provides storage when unit is used as a counter
- UPS approved



**CASE TO COUNTER CONVERSION**

Roll Wrap: ELITE-C2C-G

- available in fabric or graphic
- converts OCP Elite to a counter
- counter surface exposed



Stretch Wrap: ELITE-SW-G

- stretch fabric pullover
- converts OCP Elite to a counter
- counter surface covered by fabric

**FABRIC CHOICES**

All Coyote popup display systems are available with printed graphic murals or "velcro-friendly" fabric panels of your choice. Actual fabric color may vary slightly.

regal - smooth exhibit & display fabric



premier - ribbed exhibit & display fabric

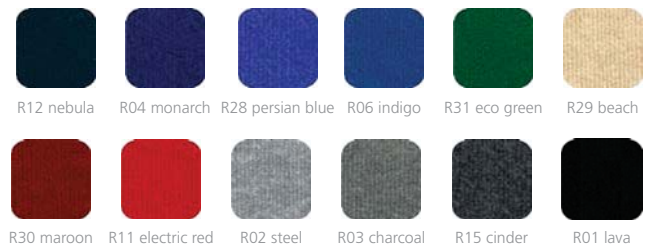

All molded Cases have a one year hardware warranty and are an eco-friendly choice.

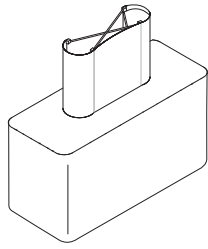

4' tabletop  
footprint dimensions:  
45.5" w x 30.625" h x 12.5" d

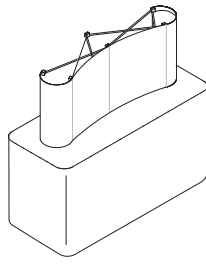

6' tabletop  
footprint dimensions:  
73" w x 30.625" h x 19.25" d

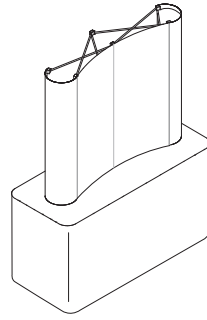

6' tabletop  
footprint dimensions:  
73" w x 59.375" h x 19.25" d

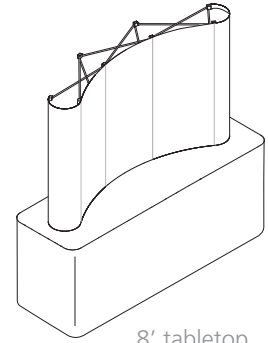

8' tabletop  
footprint dimensions:  
97.25" w x 59.375" h x 25" d

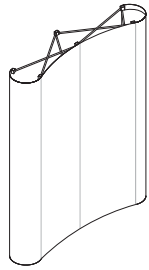

6' full height  
slim-line display system  
footprint dimensions:  
73" w x 87.56" h x 19.25" d

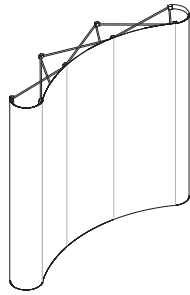

8' full height  
standard display system  
footprint dimensions:  
99.25" w x 87.56" h x 25" d

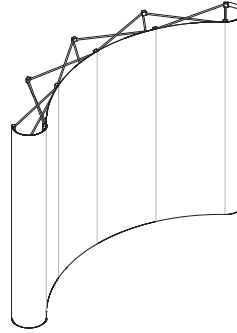

10' full height  
standard display system  
footprint dimensions:  
118" w x 87.56" h x 36.5" d

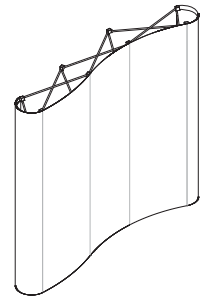

8' serpentine  
full height display system  
footprint dimensions:  
89.5" w x 87.56" h x 19.5" d

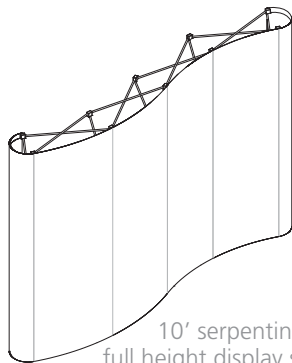

10' serpentine  
full height display system  
footprint dimensions:  
129.5" w x 87.56" h x 19.5" d

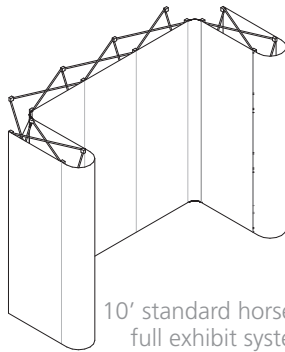

10' standard horseshoe  
full exhibit system  
footprint dimensions:  
113" w x 87.56" h x 54" d

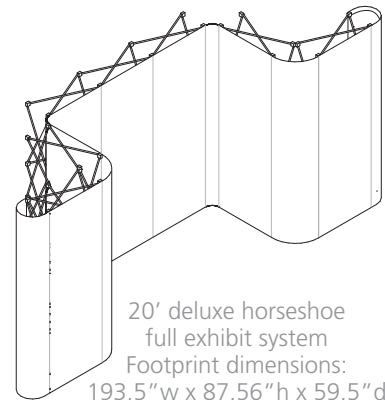

20' deluxe horseshoe  
full exhibit system  
Footprint dimensions:  
193.5" w x 87.56" h x 59.5" d

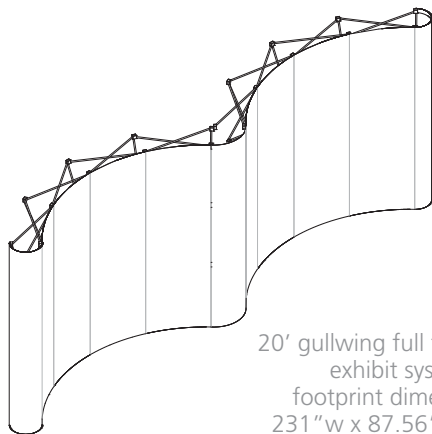

20' gullwing full trade show  
exhibit system  
footprint dimensions:  
231" w x 87.56" h x 41" d

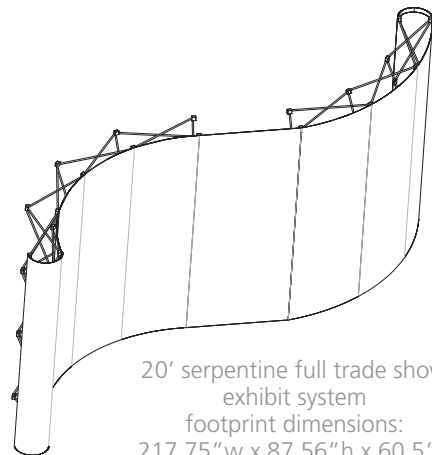

20' serpentine full trade show  
exhibit system  
footprint dimensions:  
217.75" w x 87.56" h x 60.5" d

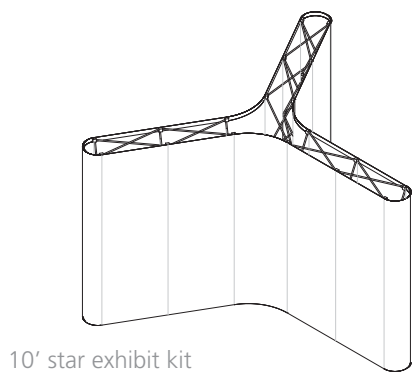

10' star exhibit kit

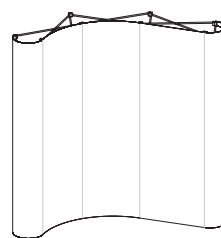
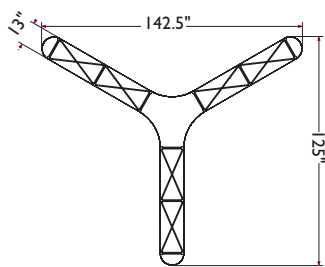

8' "L" exhibit kit

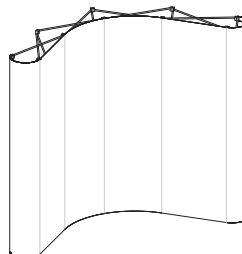
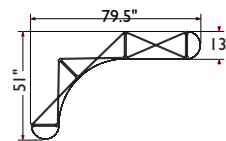

10' small "L" exhibit kit

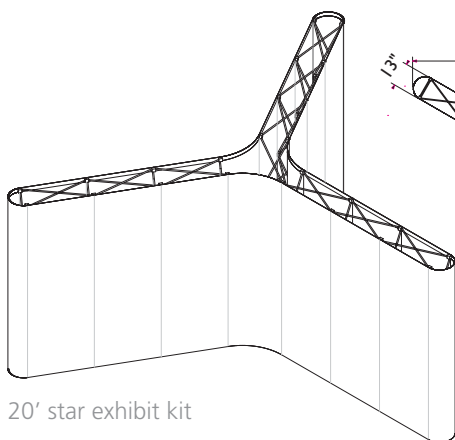
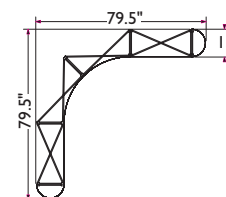

20' star exhibit kit

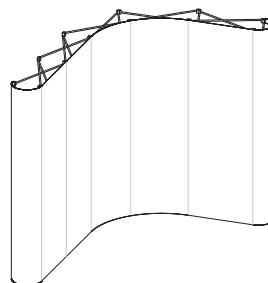
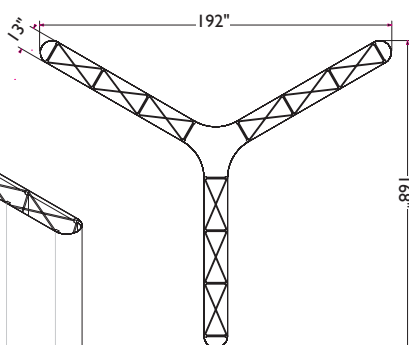

10' large "L" exhibit kit

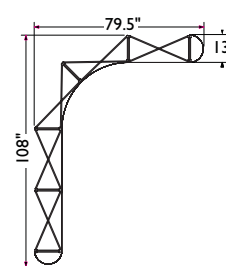

3x2 mini tabletop kit  
footprint dimensions:  
74.625" w x 48" h x 15.75" d

### COYOTE MINI

- approx. 20% smaller than standard Coyote tabletops
- entire display rolls up into special storage sleeve which slides into a padded carry case
- kit includes frame, channel bars, panel hangers, carry case, & 2 lights
- add an optional OCS hard case for shipping or extra secure storage



2x2 mini tabletop kit  
footprint dimensions:  
53.625" w x 48" h x 11.75" d





## COYOTE OPTIONS

Customize your Coyote display with a variety of optional accessories.

### COYOTE ACCENT KIT

COY-ACCT-K

- a fresh new look for your Coyote popup
- update your current display with 2 modern wing shapes and 4 extrusions



### MONITOR MOUNT

- fully integrates with straight or curved Coyote systems
- one panel cut to fit the monitor
- VESA bolt compatible
- max weight= 50lbs
- LCD max size = 23"



not recommended for plasma or CRT units



### INTERNAL SHELF KIT

- presents products or literature
- comes with 2 clear acrylic shelves to be used horizontally or at 45° angles
- max capacity per shelf = 15 lbs, max per quadrant = 45 lbs
- for use with curved frame only
- lighting package available (not to be stored with display in OCP)



### COYOTE TOWER

COY-3-G-TOW

- an unexpected addition to any display; large or small, exhibit or P.O.P.
- back-lit panels illuminate your graphics
- coordinates with the look and style of your Coyote popup display



### BUBBLE PANEL

- forward facing, convex panel
- panel can be fabric, opaque graphic or rear illuminated graphic (light kit sold separately)
- hardware can be stored with display in OCP

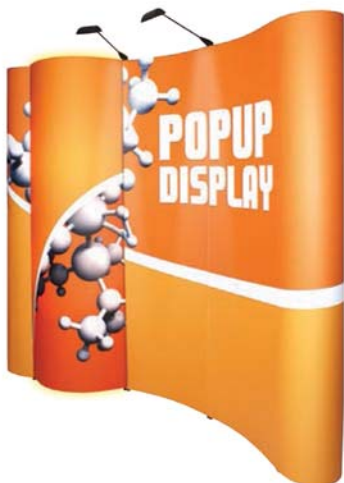

OCP case is a blow molded transit case with built in wheels, handle, and light storage in the lid.



Lumina 200 & Lumina 7 are excellent lighting solutions for your Coyote popup exhibit. (see page 72)





# FORMULATE TENSION FABRIC

Formulate backwalls are advanced aluminum structures with fabric graphics. Some kits include: front curved accents, low voltage lighting, tabletops and/or counter, literature pockets, headers and top accents. All kits come in hard molded transport case(s).



FORMULATE | TENSION FABRIC

FORMULATE TABLETOP

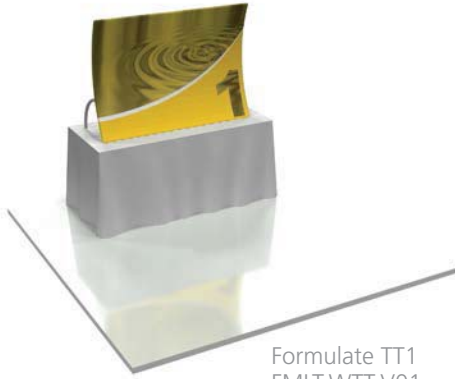

Formulate TT1  
FMLT-WTT-V01

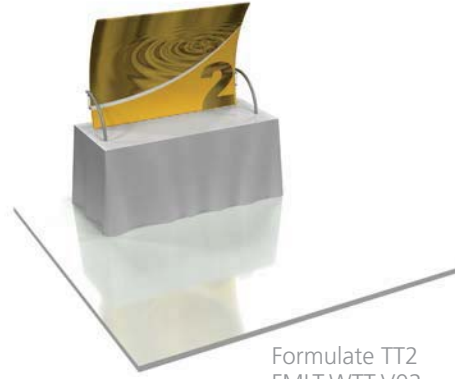

Formulate TT2  
FMLT-WTT-V02

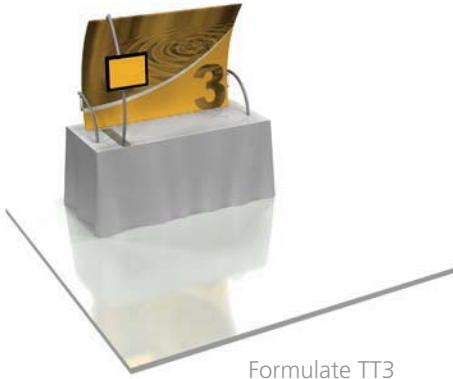

Formulate TT3  
FMLT-WTT-V03

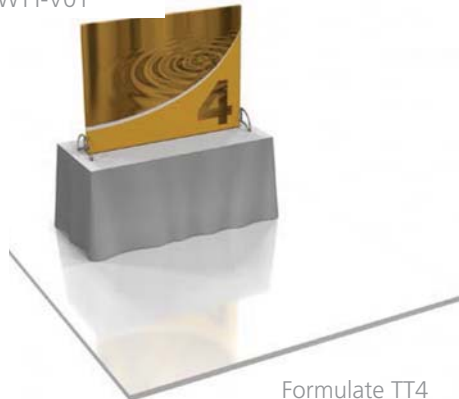

Formulate TT4  
FMLT-WTT-S01

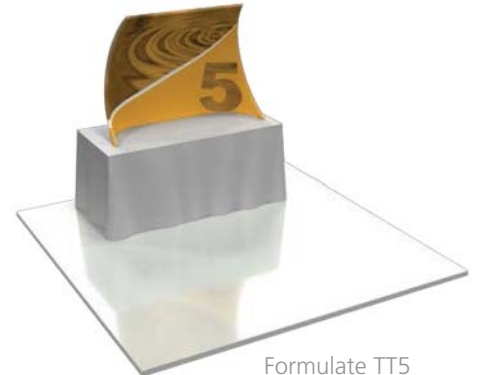

Formulate TT5  
FMLT-WTT-S02

10' FORMULATE STRAIGHT



Formulate S1  
FMLT-WS10-01



Formulate S2  
FMLT-WS10-02



Formulate S3  
FMLT-WS10-03



Formulate S4  
FMLT-WS10-04



Formulate S5  
FMLT-WS10-05

## 10' FORMULATE HORIZONTALLY CURVED



Formulate HC1  
FMLT-WH10-01



Formulate HC2  
FMLT-WH10-02

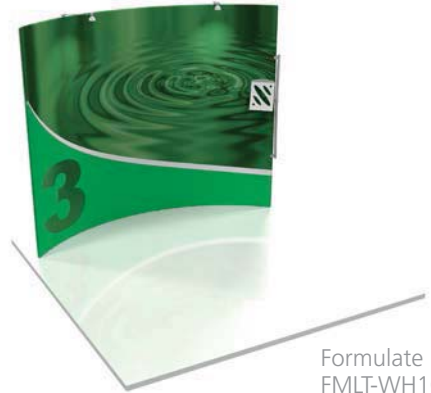

Formulate HC3  
FMLT-WH10-03

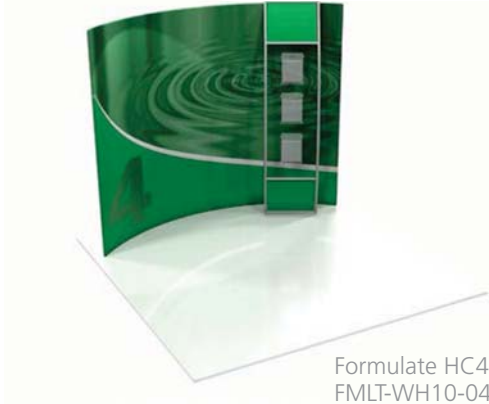

Formulate HC4  
FMLT-WH10-04

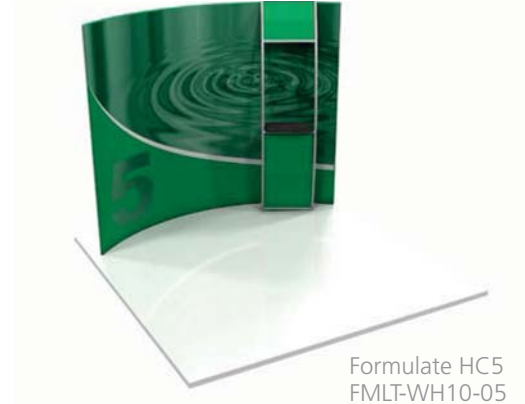

Formulate HC5  
FMLT-WH10-05

## 10' FORMULATE VERTICALLY CURVED

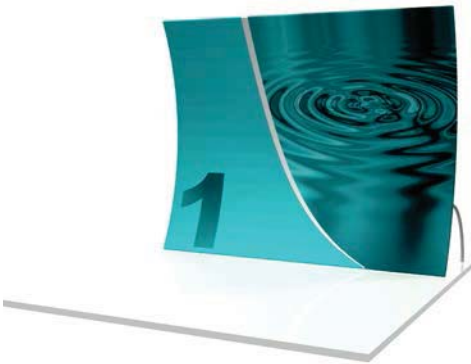

Formulate VC1  
FMLT-WV10-01

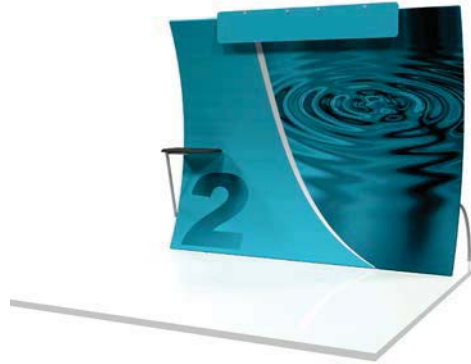

Formulate VC2  
FMLT-WV10-02



Formulate VC3  
FMLT-WV10-03



Formulate VC4  
FMLT-WV10-04



Formulate VC5  
FMLT-WV10-05

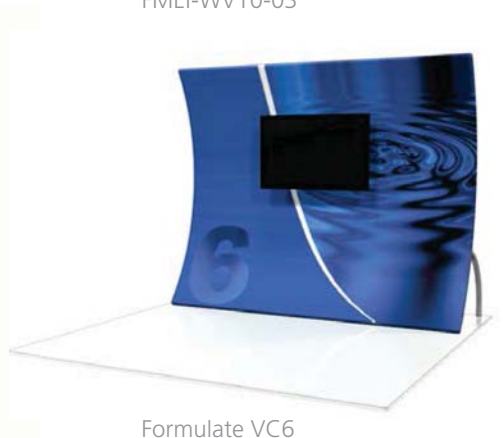

Formulate VC6  
FMLT-WV10-06



8' FORMULATE BACKWALLS



Formulate 8S  
FMLT-WS8-01



Formulate 8H  
FMLT-WH8-01



Formulate 8V  
FMLT-WV8-01

20' FORMULATE BACKWALLS



Formulate 20 Straight  
FMLT-WS20-01

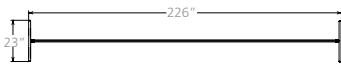

Formulate 20S  
FMLT-WSC20-01

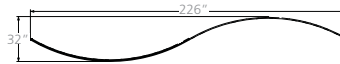

Formulate 20H  
FMLT-WH20-01

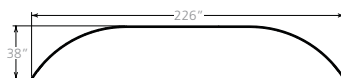

Formulate 20V  
FMLT-WV20-01





# FORMULATE HANGING STRUCTURES

## RING

- 8' diam. x 3'h
- 10'9" diam. x 4'h
- 12' diam. x 4'h
- 14' diam. x 4'h
- 16' diam. x 4'h
- 18' diam. x 4'h
- 20' diam. x 4'h

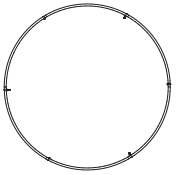

## TAPERED RING

- 8' diam. x 3'h
- 10'9" diam. x 4'h
- 12' diam. x 4'h
- 14' diam. x 4'h
- 16' diam. x 4'h
- 18' diam. x 4'h
- 20' diam. x 4'h

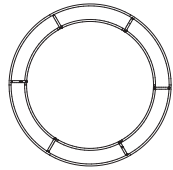

## FOUR SIDED

- 6'w x 3'h
- 8'w x 3'h
- 8'10" w x 4'h
- 12'w x 4'h
- 14'w x 4'h
- 16'w x 4'h
- 18'w x 4'h
- 20'w x 4'h

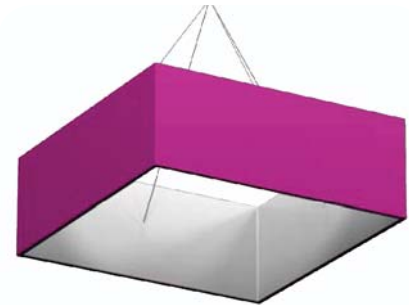
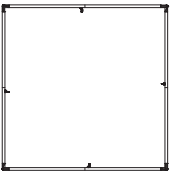

## TAPERED FOUR SIDED

- 10'w x 4'h
- 12'w x 4'h
- 16'w x 5'h
- 20'w x 5'h

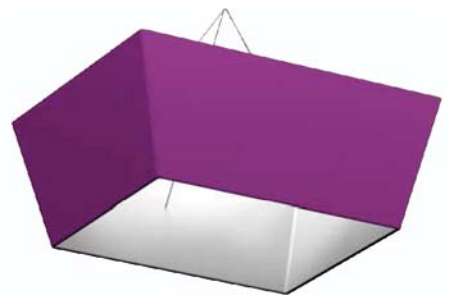
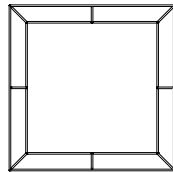

## CONCAVE FOUR SIDED

- 8'10" w x 3'h
- 8'10" w x 4'h
- 12'w x 4'h
- 14'w x 4'h
- 16'w x 4'h
- 18'w x 4'h
- 20'w x 4'h

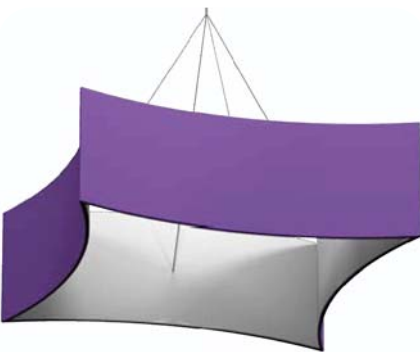

## THREE SIDED

- 6'w x 3'h
- 8'10" w x 4'h
- 10'w x 4'h
- 12'w x 4'h
- 14'w x 4'h
- 16'w x 4'h
- 18'w x 4'h
- 20'w x 4'h

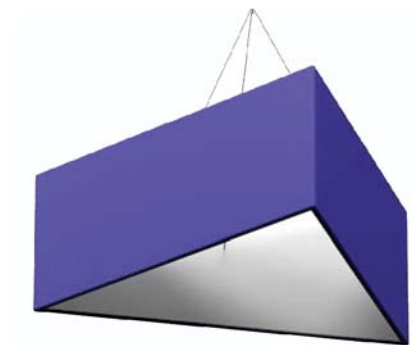
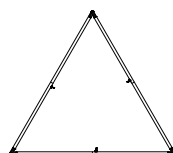

All Formulate structures come with hanging hardware and a lifetime hardware warranty. Cases available upon request. Custom sizes also available.

**TAPERED THREE SIDED**

- 10'w x 4'h
- 12'w x 4'h
- 16'w x 5'h
- 20'w x 5'h

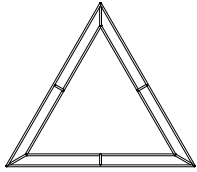

**CONVEX THREE SIDED**

- 8'9" w x 3' h
- 8'9" w x 4' h
- 12' w x 4' h
- 15' w x 4' h
- 20' w x 5' h

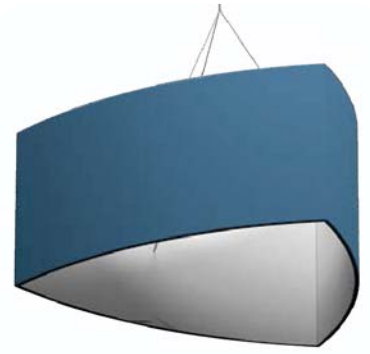
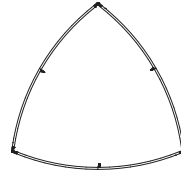

**PINWHEEL**

- 8'9" w x 3' h
- 8'9" w x 4' h
- 12' w x 4' h
- 16' w x 4' h
- 20' w x 4' h
- 20' w x 5' h

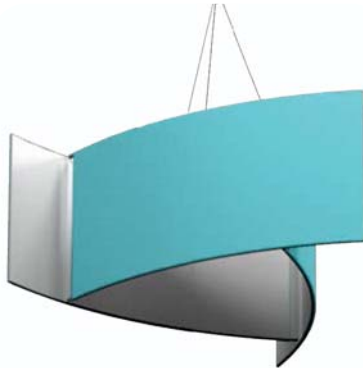

**RECTANGLE**

- 12' l x 6' w x 4' h
- 16' l x 8' w x 5' h
- 20' l x 10' w x 5' h

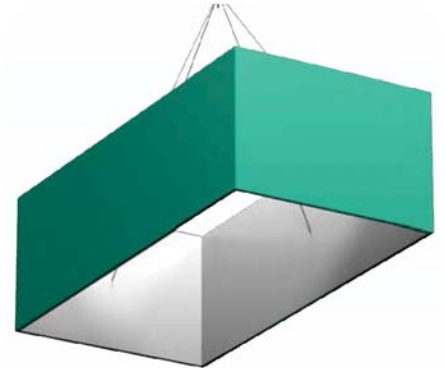

**FOOTBALL**

- 8'9" l x 3' h
- 8'9" l x 4' h
- 12' l x 4' h
- 15' l x 4' h
- 20' l x 5' h

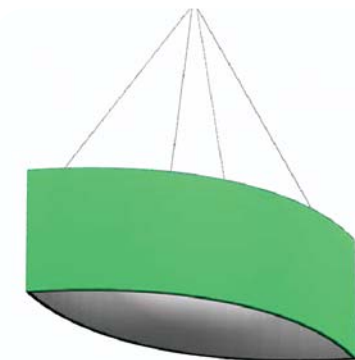

**FOUR SIDED PYRAMID**

- 10' w x 5' h
- 12' w x 6' h
- 16' w x 8' h
- 20' w x 10' h

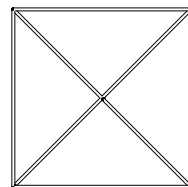

**THREE SIDED PYRAMID**

- 10'w x 5'h
- 12'w x 6'h
- 16'w x 8'h
- 20'w x 10'h

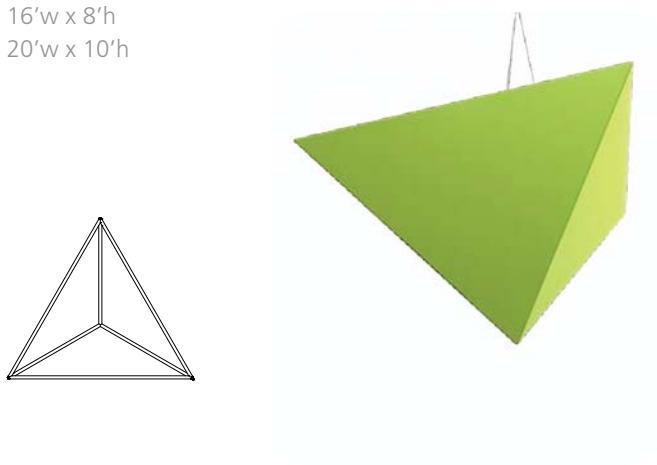

**ROUND FUNNEL**

- 10'w x 4'h

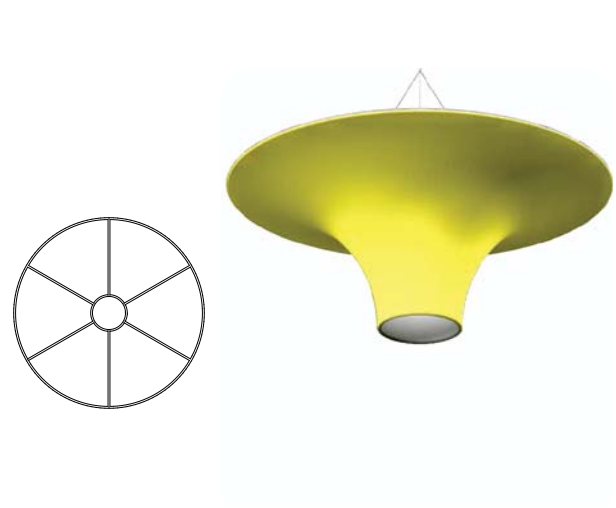

**SQUARE FUNNEL**

- 10'w x 4'h

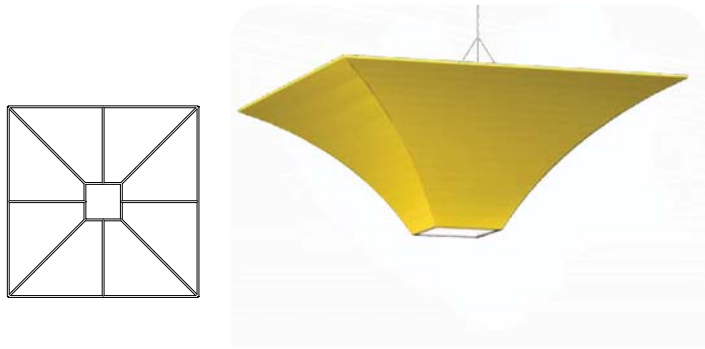

**CONE**

- 10'w x 5'h
- 12'w x 6'h
- 16'w x 8'h
- 20'w x 10'h

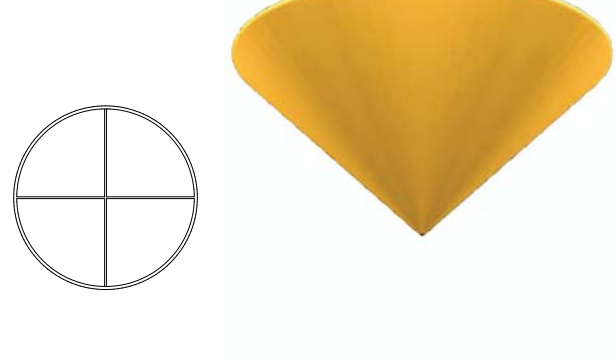

**CURVE**

- 8'w x 3'h
- 8'9" w x 4'h
- 12'w x 4'h
- 15'w x 4'h
- 16'w x 4'h
- 20'w x 4'h
- 20'w x 6'h

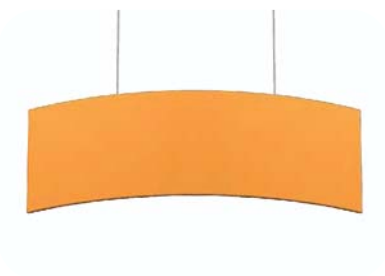

**PANEL**

- 6'w x 3'h
- 8'w x 3'h
- 8'9" w x 4'h
- 12'w x 4'h
- 15'w x 4'h
- 16'w x 4'h
- 20'w x 4'h
- 20'w x 6'h

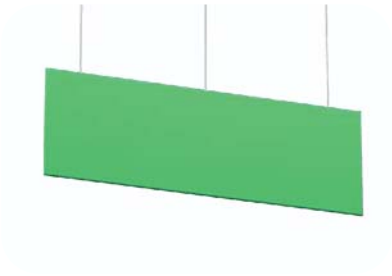

**DISC**

- 8' diameter
- 10'9" diameter
- 12' diameter
- 14' diameter
- 16' diameter
- 18' diameter
- 20' diameter

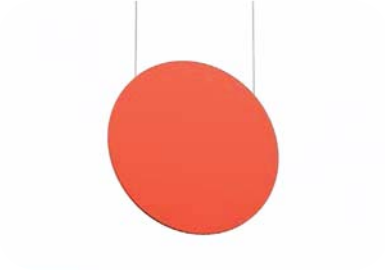

**S-CURVE**

- 8'w x 3'h
- 12'w x 4'h
- 12'w x 6'h
- 15'6" w x 4'h
- 16'w x 4'h
- 16'w x 6'h
- 20'w x 6'h



All Formulate structures come with hanging hardware and a lifetime hardware warranty. Cases available upon request. Custom sizes also available.

VIBE



Vibe is a collection of cleverly-designed state-of-the-art 10' exhibit booths. Vibe combines light-weight aluminum structures with pillowcase dye-sublimated printed fabric graphics for a truly unique appearance and experience.



**KIT 01**  
VBK-1



**KIT 02**  
VBK-2

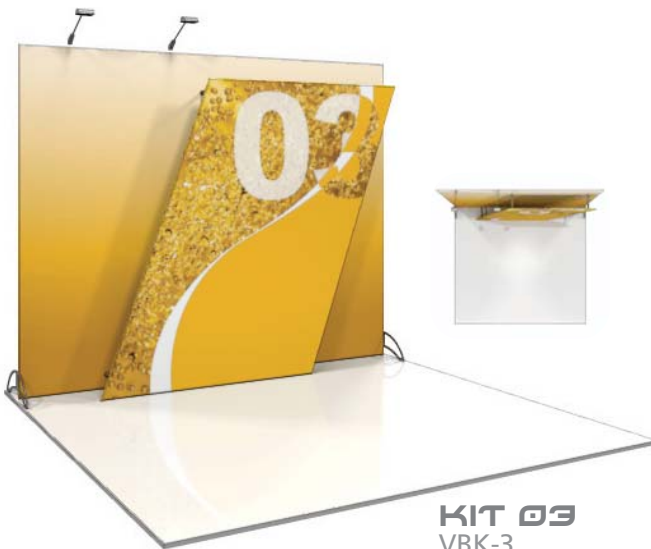

**KIT 03**  
VBK-3



**KIT 04**  
VBK-4

VIBE | TENSION FABRIC



**VIBE**

Vibe is a collection of cleverly-designed state-of-the-art 10' exhibit booths. Vibe combines light-weight aluminum structures with pillowcase dye-sublimated printed fabric graphics for a truly unique appearance and experience.

VIBE | TENSION FABRIC



**KIT 05**  
VBK-5



**KIT 06**  
VBK-6

Vibe counter tops are available in your choice of four thermoform finishes



silver black mahogany natural

Vibe counter bases are available in your choice of four laminate options



dove gray black designer white fusion maple



**VIBE COUNTER 01**  
VB-01

- 64" w x 40" h x 20" d
- approx. weight with OCH2 case: 120 lbs
- custom colors available upon request



**VIBE COUNTER 02**  
VB-02

- 46" w x 40" h x 20" d
- approx. weight with OCH2 case: 120 lbs
- custom colors available upon request



**VIBE COUNTER 03**  
VB-03

- 46" w x 40" h x 20" d
- approx. weight with OCH2 case: 120 lbs
- custom colors available upon request



**VIBE MONITOR KIOSK**  
VB-MK-01

- metal structure
- medium monitor bracket, max weight: 50 lbs (monitor not included)
- OCH2 case

**TABLE THROW**

- 4' full: TBL-T-4-F
- 4' economy: TBL-T-4-E
- 6' full: TBL-T-6-F
- 6' economy: TBL-T-6-E
- 8' full: TBL-T-8-F
- 8' economy: TBL-T-8-E

- complete your presentation with a premium printed table throw
- lends a polished appearance to any display
- maximize your advertising with additional space to display your message



shown with Horizon Standard tabletop folding panel display (see page 38)



4' table throws now available for smaller tables



**TABLE RUNNERS**

- 24" full: TBL-R-24-F
- 24" economy: TBL-R-24-E
- 30" full: TBL-R-30-F
- 30" economy: TBL-R-30-E
- 60" full: TBL-R-60-F
- 60" economy: TBL-R-60-E

- accent your solid colored table throw with a full color printed runner
- available in 3 widths



**CONVERTIBLE TABLE THROW**

- convertible full: TBL-T-FC
- convertible economy: TBL-T-EC

- converts quickly and easily to fit both a 6' and 8' table
- Velcro tabs make conversion simple



## IMPRINTED TABLE THROW

- 6' full
- 6' economy
- 8' full
- 8' economy

- 11 standard tablethrow colors
- maximum logo size = 60" w x 21.5" h (see template for details)
- must be simple vector artwork, no complex logos or gradients
- referenced Pantone colors are not exact



carry bag available  
TBL-THRW-BG



full table throw shown in white fabric with blue and sapphire imprinted vinyl



economy table throw leaves back of table exposed for easy access to storage

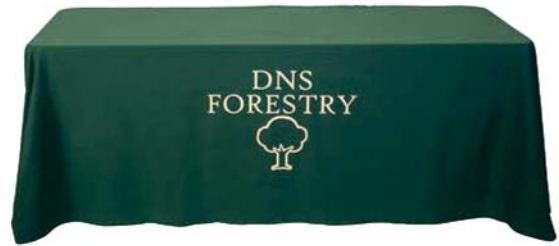

imprinted table throw is shown with the 1 color option

## ECONOMY TABLE THROW

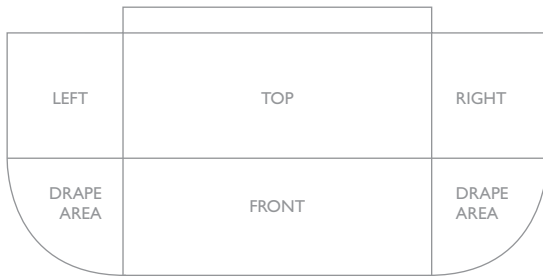

## FULL TABLE THROW

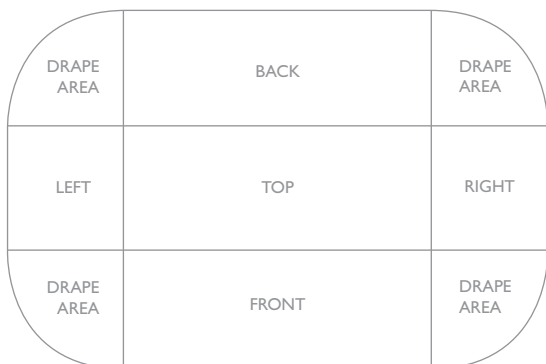

## FABRIC COLORS



## VINYL COLORS



All table throws and runners come with a graphic limited warranty of 6 months and are made in the U.S.A.

# HORIZON



- main panel sizes approximately = 24" w x 36" h
- custom sized panel displays are available
- shown with optional detachable graphics
- available in a variety of fabric color options (page 39)



**WEIGHS** 22 LBS  
Horizon 6  
HZ-6



**WEIGHS** 12 LBS  
Horizon 3  
HZ-TT-S



**WEIGHS** 13.5 LBS  
Horizon 5  
HZ-TT-M



**WEIGHS** 31 LBS  
Horizon 8  
HZ-8

## TT

black & grey: TT-D-4-BK/GRY  
blue & grey: TT-D-BL/GRY

- lightweight, fabric covered tabletop display
- individual panels = 18.19" w x 22.69" h
- available in 2 front & back color combinations: black/grey, blue/grey (shown with optional graphic panels)

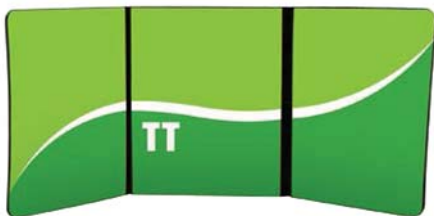

## EFEX

2801 three panel kit:  
EFX-2801  
2802 three panel kit w/header:  
EFX-2802

- lightweight, fabric covered tabletop display
- individual panels = 28" w x 35" h
- available in a choice of 4 basic color combinations:

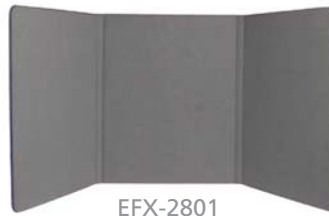

EFX-2801

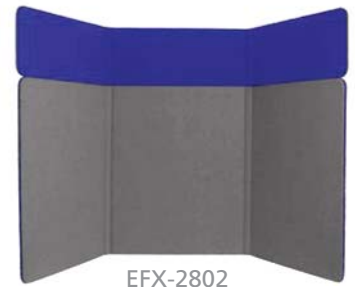

EFX-2802

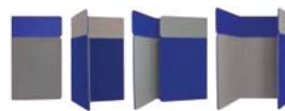



# HERO



- durable premium seamless exhibit panel kits
- convenience of folding panels with elegant, seamless panel construction
- concealed hinges
- unique 2" radius curved ends lend a polished appearance
- full height units can also be used as two tabletop units
- available in a variety of fabric color options
- shown with optional detachable graphics



fits in an OCH case  
(case not included)



shown with optional graphics  
HERO H16

3'11" HIGH

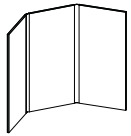

HERO H02-1  
tabletop display

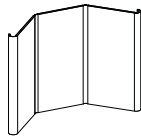

HERO H02-2  
tabletop display with  
curved end caps

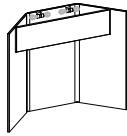

HERO H03  
tabletop display with  
backlit header

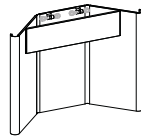

HERO H04  
tabletop display with backlit  
header and curved end caps

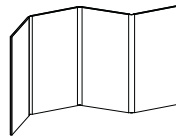

HERO H05  
tabletop display



HERO H08  
tabletop display with backlit  
header and curved end caps

7'10" HIGH

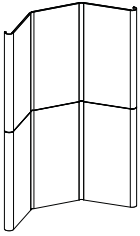

HERO H09  
full height exhibit with  
curved end caps

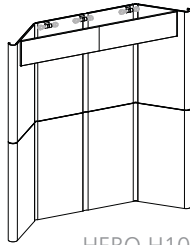

HERO H10  
full height exhibit with curved  
end caps and backlit header

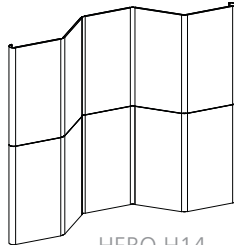

HERO H14  
full height exhibit with  
curved end caps

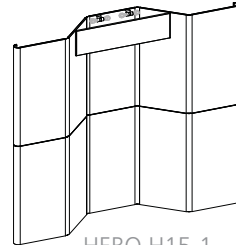

HERO H15-1  
full height exhibit with  
curved end caps & backlit  
header

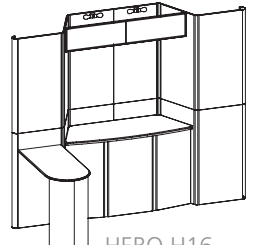

HERO H16  
10' full height exhibit kit with  
curved end caps, backlit  
header & peninsula

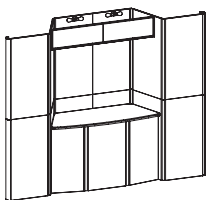

HERO H17  
10' full height exhibit kit with  
curved end caps & backlit header

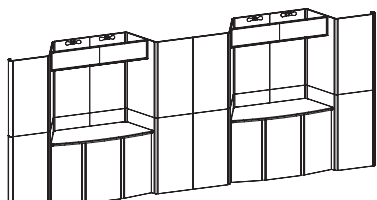

HERO H18  
20' full height exhibit kit with  
curved end caps & backlit header

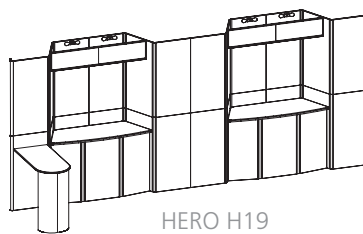

HERO H19  
20' full height exhibit kit with  
curved end caps, backlit header  
& one peninsula

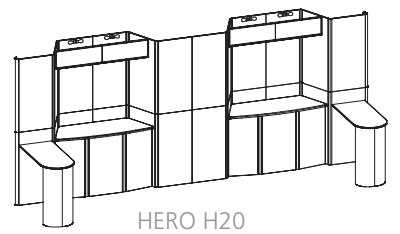

HERO H20  
20' full height exhibit kit with  
curved end caps, backlit header  
& two peninsulas

## FABRIC CHOICES

All Horizon & Hero display systems are available with printed graphic murals or "velcro-friendly" fabric panels of your choice. Actual fabric color may vary slightly.

regal - smooth exhibit & display fabric



premier - ribbed exhibit & display fabric



**VOYAGER**



The Voyager has been specially developed as a briefcase style table top display and is a great choice for promotions on the go. It has a rigid, thermo formed ABS exterior and a black, Velcro compatible fabric interior.

Detachable graphics allow for easy changes! Headers shown are an additional option. Extra graphics can be stored in the display case and packed away for easy storage.



FOLDING DISPLAY PANELS

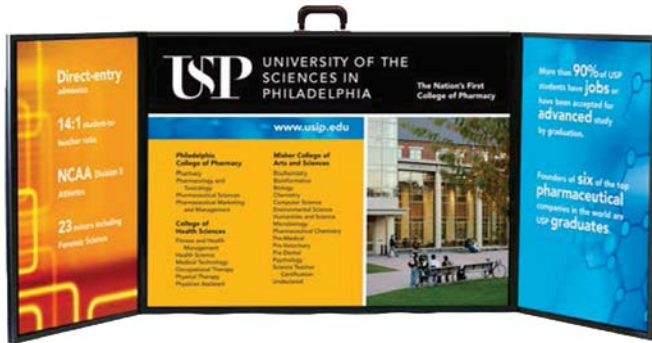

WEIGHS 5 LBS **VY 1**

Voyager Mini Kit (small)  
open dimensions: 48" w x 18" h  
closed dimensions: 24" w x 18" h



WEIGHS 6.5 LBS **VY 2**

Voyager Maxi Kit (medium)  
open dimensions: 48" w x 24" h  
closed dimensions: 24" w x 24" h

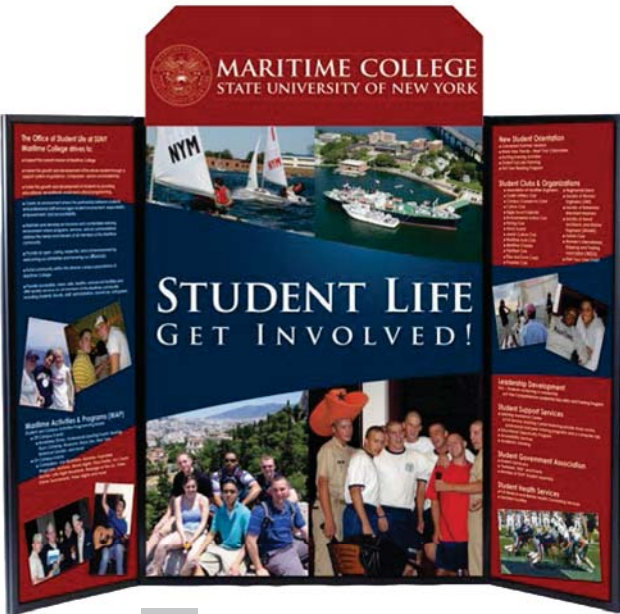

WEIGHS 8.25 LBS **VY 3**

Voyager Mega Kit (large)  
open dimensions: 48" w x 32" h  
closed dimensions: 24" w x 32" h



WEIGHS 8.25 LBS **VY 4**

Voyager Supreme kit (x-large)  
open dimensions: 64" w x 24" h  
closed dimensions: 32" w x 24" h

## CUSTOMIZE

Brand the exterior of your Voyager to match your company and/or product colors to maximize your marketing efforts. Minimum 12 units, call for details.

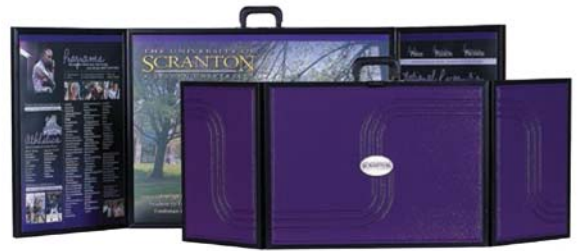

WEIGHS  
10 LBS

**VY 5**

Voyager Monster kit (xx-large)  
open dimensions: 64" w x 32" h  
closed dimensions: 32" w x 32" h



## VOYAGER CARRY BAG

Voyager Mini bag:	VY-1-BG	
Voyager Maxi bag:	VY-2-BG	
Voyager Mega bag:	VY-3-BG	
Voyager Supreme bag:	VY-4-BG	
Voyager Monster bag:	VY-5-BG	



# ORBITAL EXPRESS TRUSS



The Orbital Express Truss System requires NO TOOLS for set up! Installation couldn't be easier, simply twist & lock. The specially designed connectors are simple to use, strong & secure. Our truss kits can be reconfigured in multiple ways using the same parts. Have a different exhibit for each show! We offer more than 60 professionally designed "off the shelf" kits for a variety of booth sizes and configurations. Each kit comes complete with all the parts, fixtures and fittings you need to create a successful exhibit, including (depending on the kit) low voltage spotlights and adjustable tabletops.



**SIRIUS**  
10'x10'  
KIT OR-K-SR1

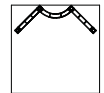

### ARA

10'x10'  
KIT OR-K-AA1



### VELA-2

10'x10'  
KIT OR-K-VL1-2



backwall  
height = 72.5"

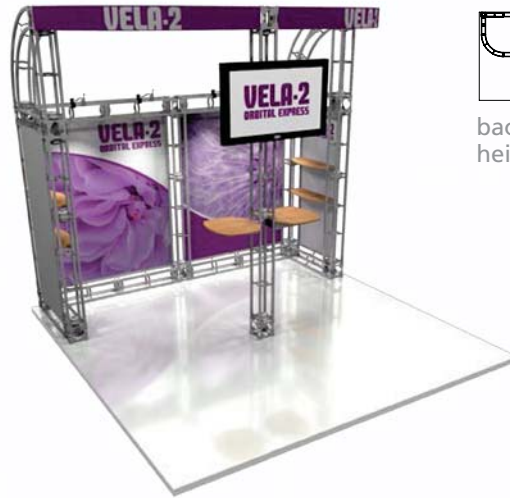

### CETUS

10'x10'  
KIT OR-K-CT1

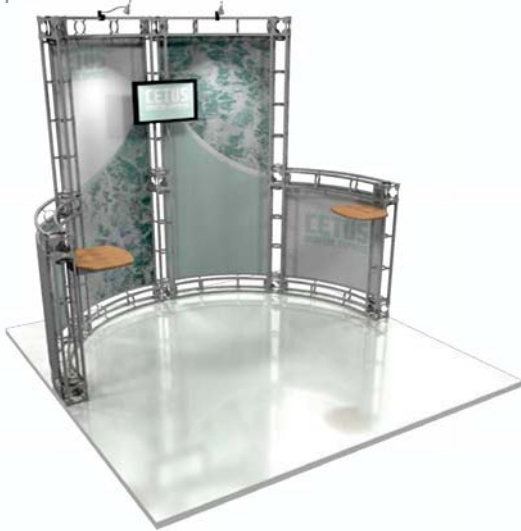

### LYRA

10'x10'  
KIT OR-K-LY1  
corner kit

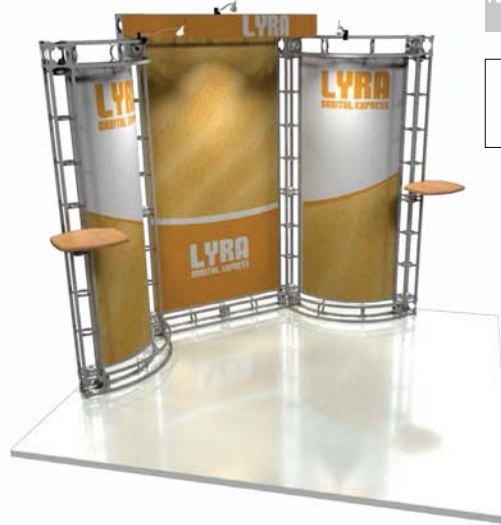

### CARINA

10'x10'  
KIT OR-K-CR1

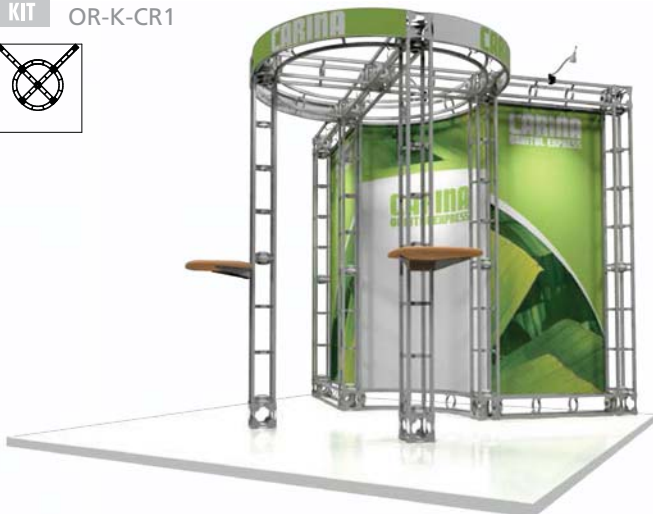

### CASTOR

10'x10'  
KIT OR-K-CS1

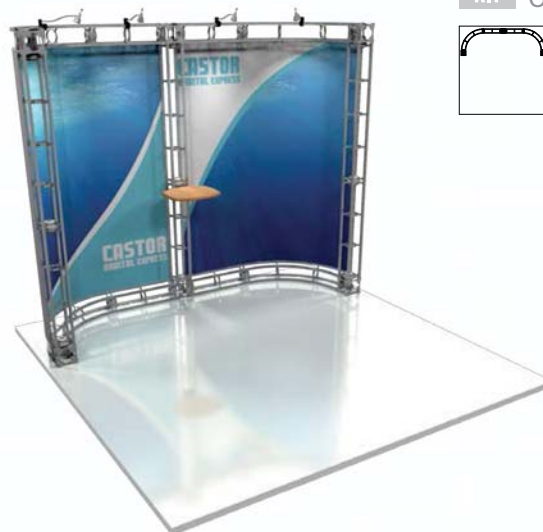

**CYGNUS**

10'x10' KIT OR-K-SYG2 corner kit



**PLUTO**

10'x10' KIT OR-K-PL1

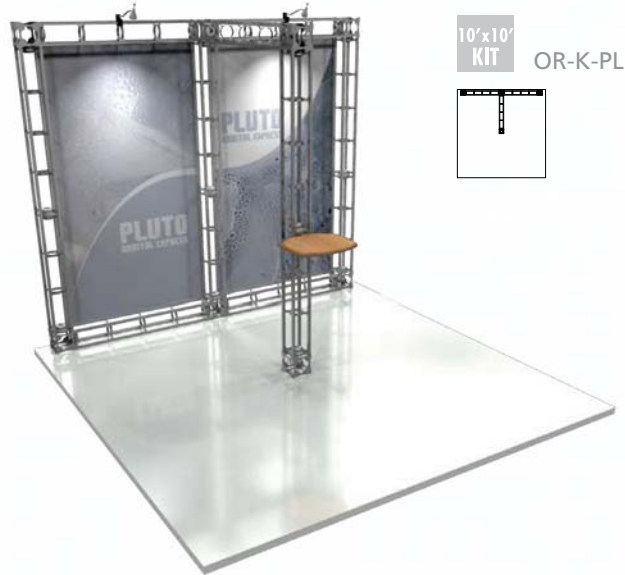
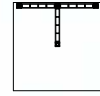

**MERCURY**

10'x10' KIT OR-K-ME1

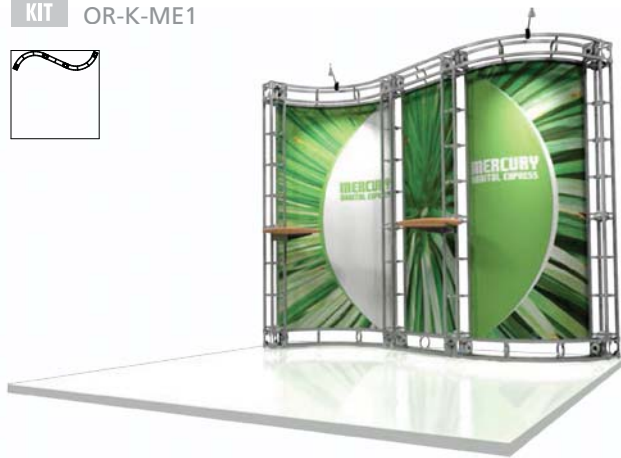

**LYNX**

10'x10' KIT OR-K-LX1

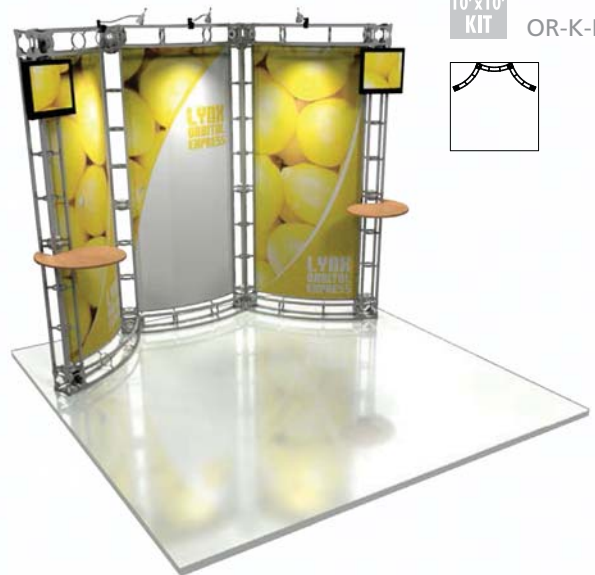
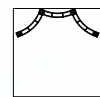

**MARS**

10'x10' KIT OR-K-MR1

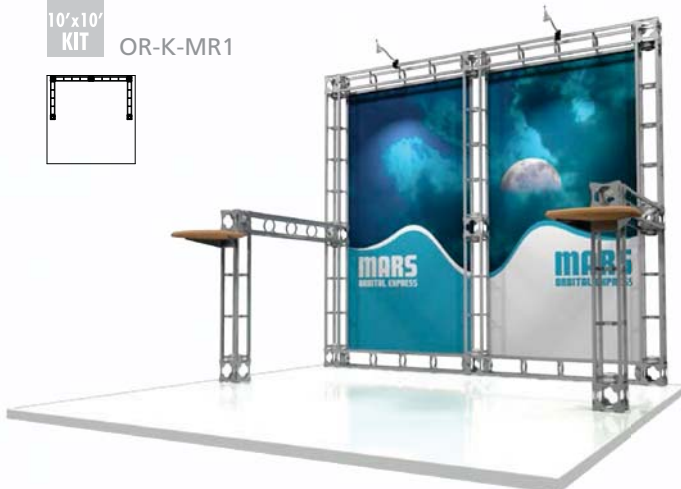

**PAVO**

10'x10' KIT OR-K-PA1

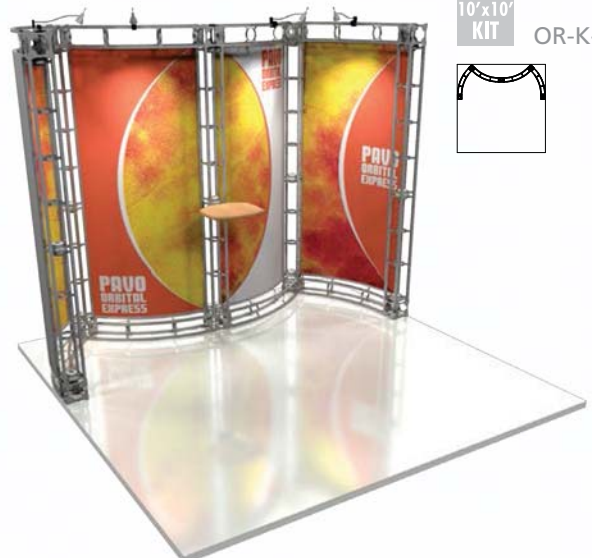
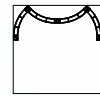

## CEPHEUS-2

10' x 20'  
KIT

OR-K-CE1-2

backwall height = 72.5"

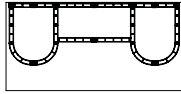

## THETA

10' x 20'  
KIT

OR-K-TH1



## PICTOR

10' x 20'  
KIT

OR-K-PC1

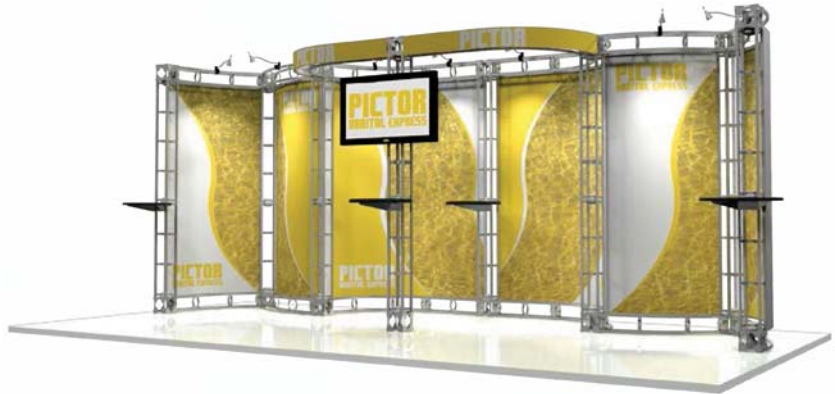
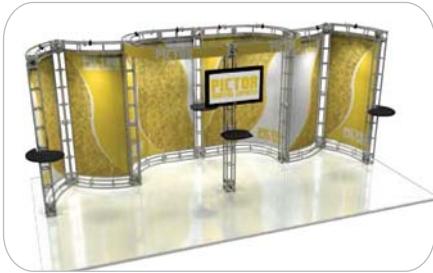
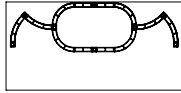

## INDUS

10' x 20'  
KIT

OR-K-IN1

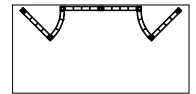

### ANTARES

10'x20'  
KIT

OR-K-AT1

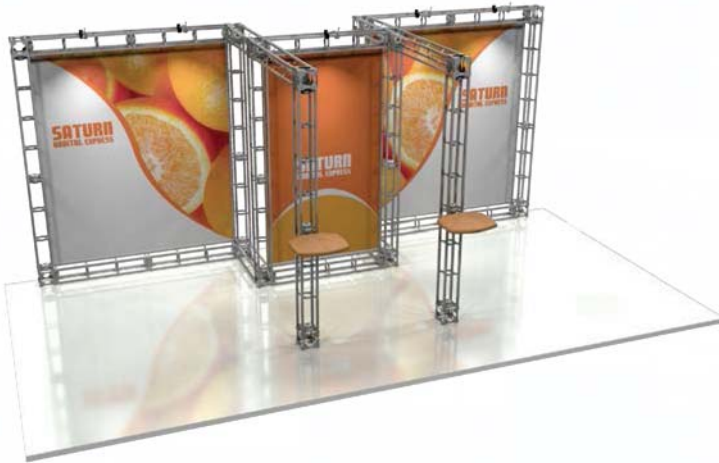
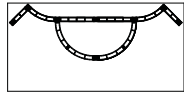

### SATURN

10'x20'  
KIT

OR-K-SA1

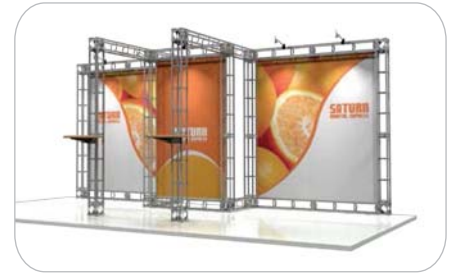
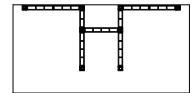

### ELECTRA

10'x20'  
KIT

OR-K-EL1

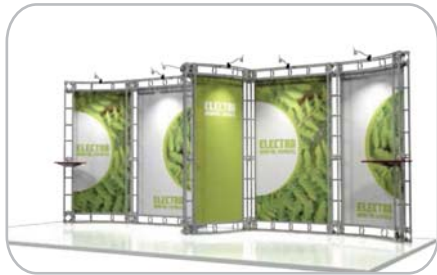
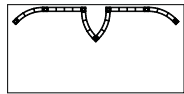

### PHOENIX

10'x20'  
KIT

OR-K-PX1

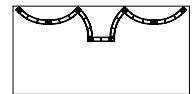



**POLARIS**

10' x 20'  
KIT OR-K-PR1

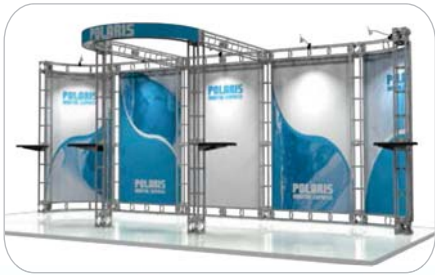
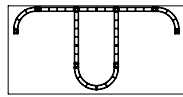

**OMICRON**

10' x 20'  
KIT OR-K-OM1

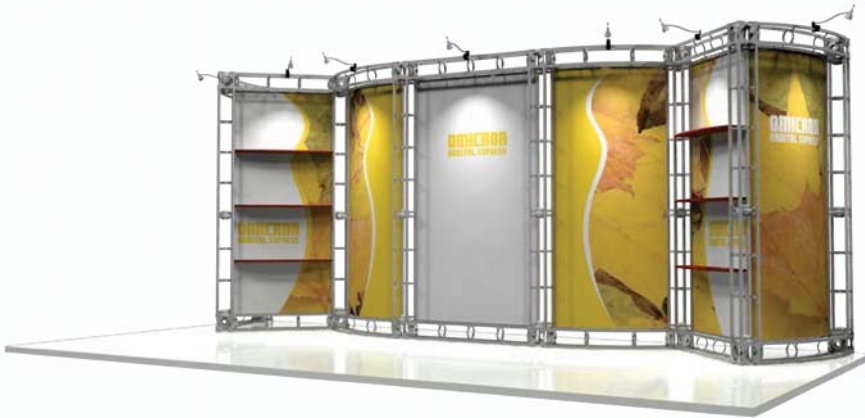
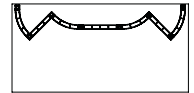

**ANDROMEDA**

10' x 20'  
KIT OR-K-AD1

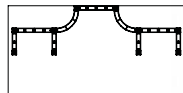

**ARCTURUS**

10' x 20'  
KIT OR-K-AR1

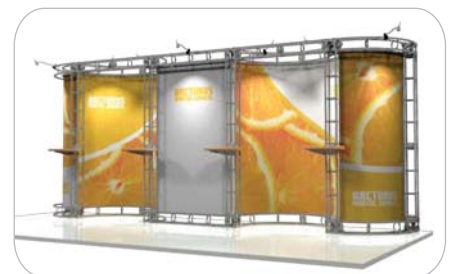
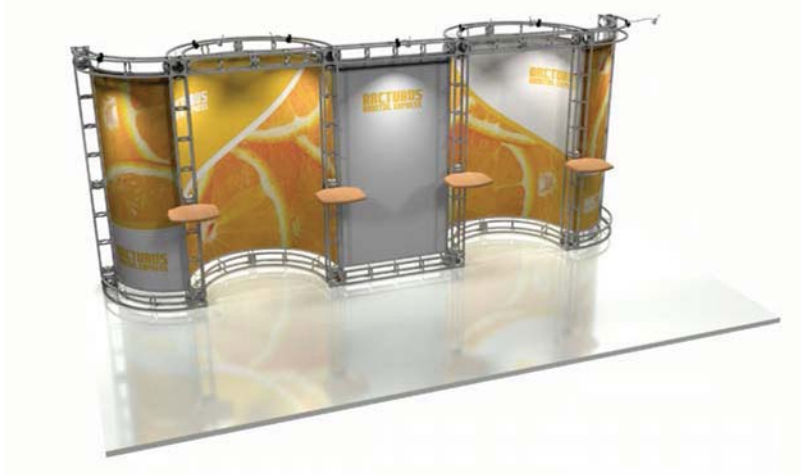
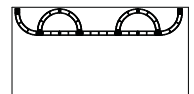

**VENUS**

10'x20'  
KIT OR-K-VE1

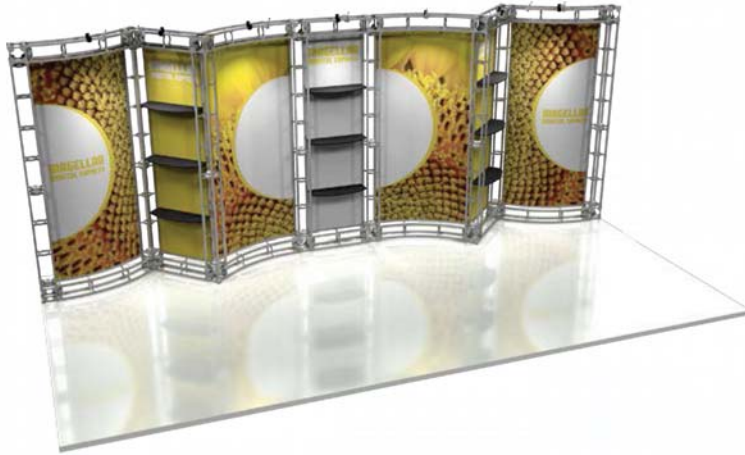
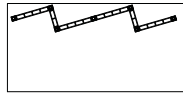

**MAGELLAN**

10'x20'  
KIT OR-K-MG1

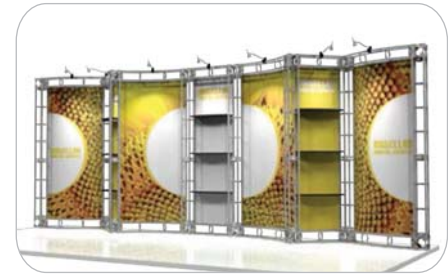
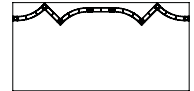

**HYDRUS**

10'x20'  
KIT OR-K-HD1

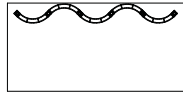

**LEO**

20'x20'  
KIT OR-K-LE1

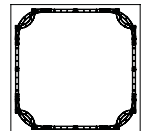

# DORADO

20'x20'  
KIT OR-K-DO1

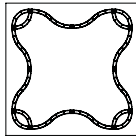

# CORVUS

20'x20'  
KIT OR-K-CV1

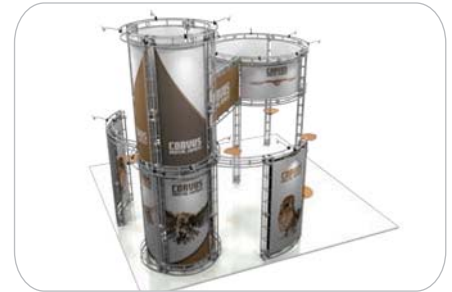
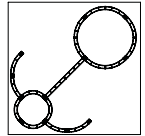

# CENTAURUS

20'x20'  
KIT OR-K-CN1

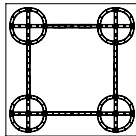

# NEPTUNE

20'x20'  
KIT OR-K-NP1

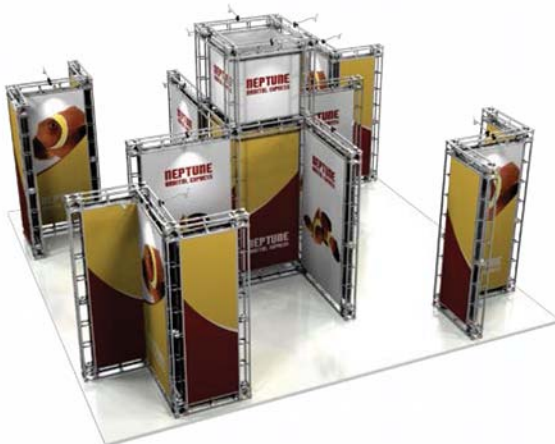
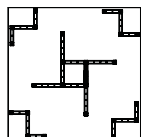

tower also sold  
separately:  
OR-K-NET

**TUCANA**

20'x20'  
KIT OR-K-TU1

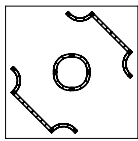

tower also sold separately: OR-K-TUT



**ORION**

20'x20'  
KIT OR-K-OR1

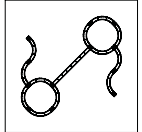

**VEGA**

20'x20'  
KIT OR-K-VG1

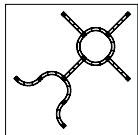

**ALTAIR**

20'x20'  
KIT OR-K-AL1

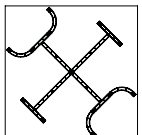



**CANIS**

20'x20'  
KIT OR-K-CA1

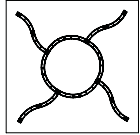

**DRACO**

20'x20'  
KIT OR-K-DR1

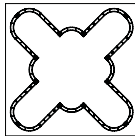

**JUPITER**

20'x20'  
KIT OR-K-JP1

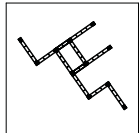

**CASSIOPEIA**

20'x20'  
KIT OR-K-CP1

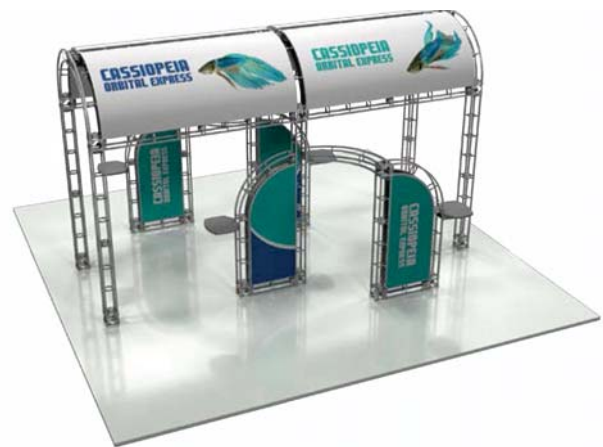
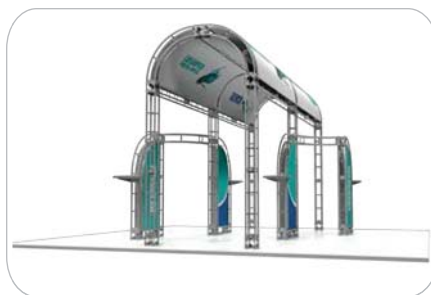
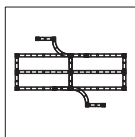

# ATLANTIS

Atlantis truss backwalls offer a unique look. The shelving and monitor brackets allow for a professional looking displays. There are no tools necessary with the simple twist-lock construction. Atlantis kits are made with sturdy feet make these stand-alone backwalls possible.



Atlantis counter tops are available in your choice of four thermoform finishes



Atlantis Kit 03  
OR-K-ATL3



Atlantis Kit 01  
OR-K-ATL1



Atlantis Kit 02  
OR-K-ATL2

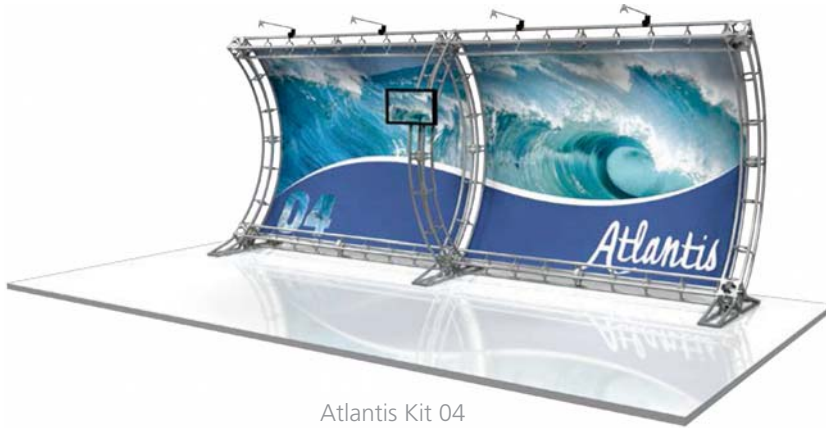

Atlantis Kit 04  
OR-K-ATL4

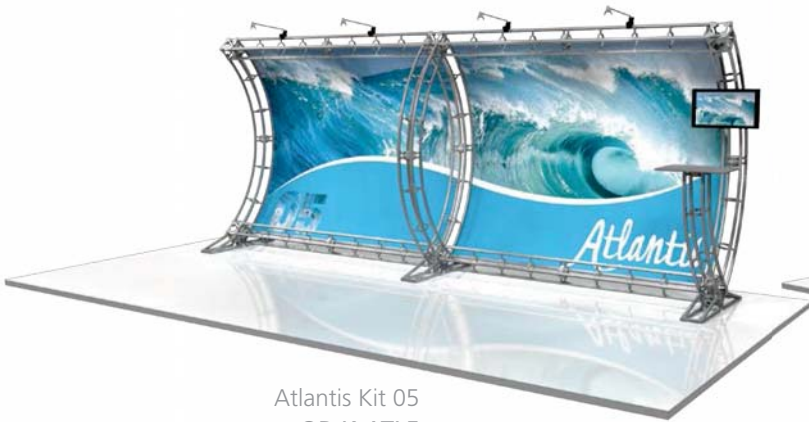

Atlantis Kit 05  
OR-K-ATL5

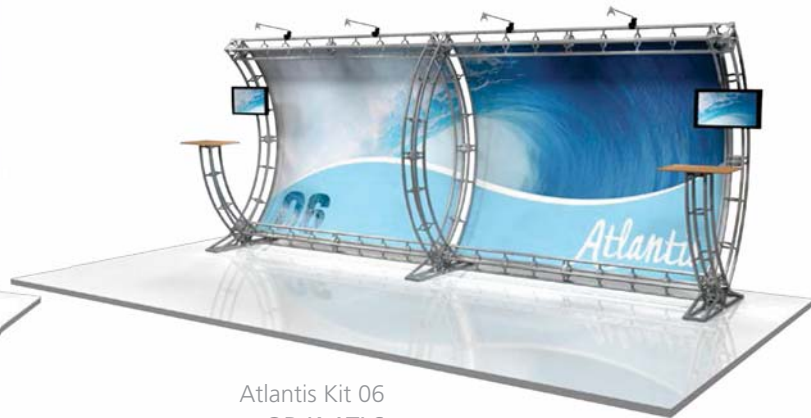

Atlantis Kit 06  
OR-K-ATL6

# HERCULES



Hercules truss backwalls offer a unique look. The shelving and monitor brackets allow for a professional looking displays. There are no tools necessary with the simple twist-lock construction. Hercules kits are made with sturdy feet make these stand-alone backwalls possible.

Hercules counter tops are available in your choice of four thermoform finishes

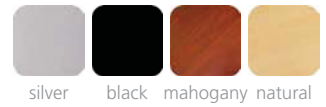

Hercules Kit 01  
OR-K-HC01

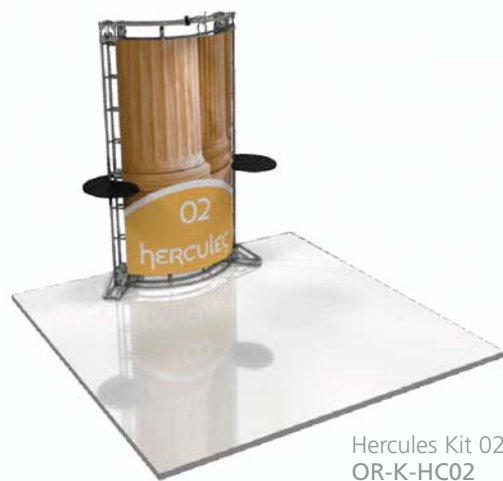

Hercules Kit 02  
OR-K-HC02



Hercules Kit 03  
OR-K-HC03



Hercules Kit 04  
OR-K-HC04



Hercules Kit 05  
OR-K-HC05

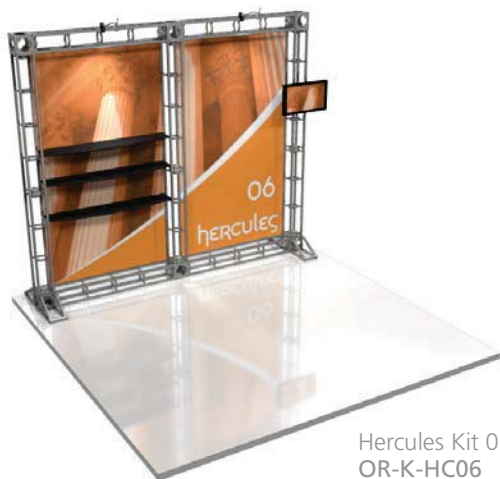

Hercules Kit 06  
OR-K-HC06

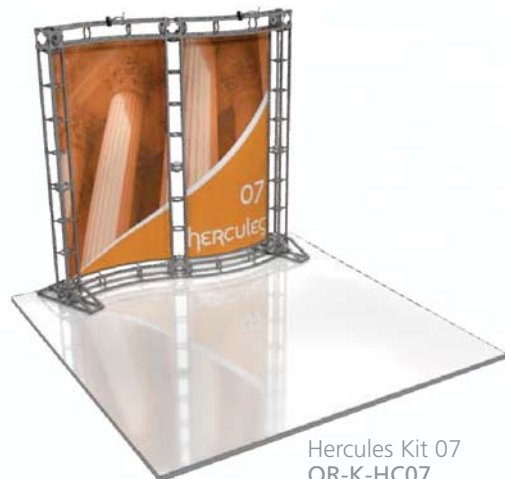

Hercules Kit 07  
OR-K-HC07





Hercules Kit 08  
OR-K-HC08

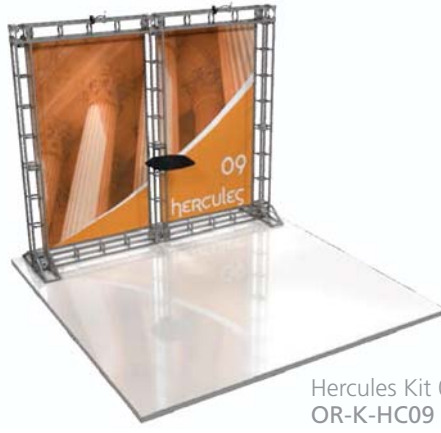

Hercules Kit 09  
OR-K-HC09

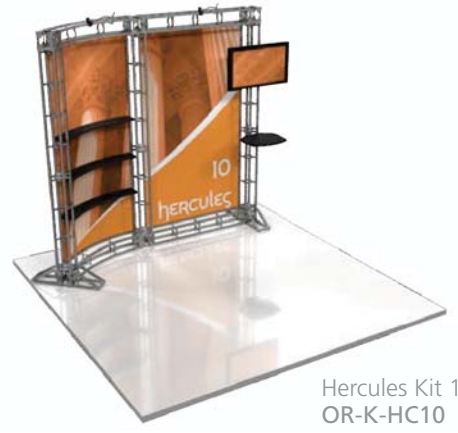

Hercules Kit 10  
OR-K-HC10



Hercules Kit 11  
OR-K-HC11



Hercules Kit 12  
OR-K-HC12



Hercules Kit 13  
OR-K-HC13



Hercules Kit 14  
OR-K-HC14

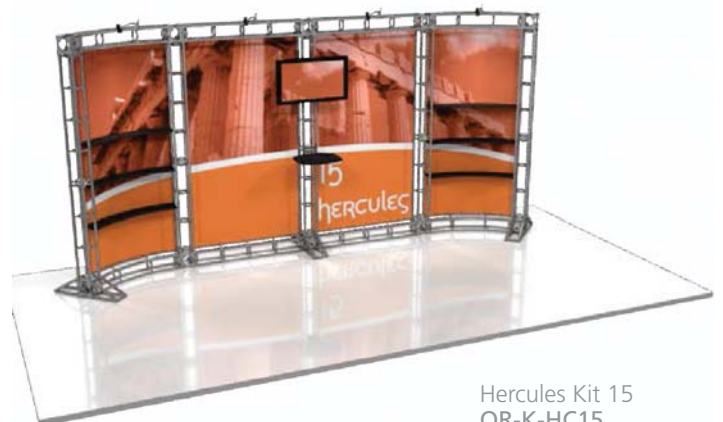

Hercules Kit 15  
OR-K-HC15

# ORBITAL TRUSS COUNTERS & PODIUMS

Truss Counters & Podiums have several attractive designs to choose from with a sleek plex top as an available option. Choose from 4 tabletop colors. Graphic options are also available for Truss Counters. No tools needed for assembly.







Truss counter tops are available in your choice of four thermoform finishes



shown with optional front graphic panel



plex accent attaches with screw-on stand-offs



optional OCH2 case available on page 70

**RECTANGLE**



OR-TC01  
rectangle - standard



OR-TC01-P  
rectangle - with plex  
stand-off and internal shelf

**OVAL**



OR-TC02  
oval - standard



OR-TC02-P  
oval - with plex stand-off  
and internal shelf

**RACETRACK**



OR-TC03  
racetrack - standard



OR-TC03-P  
racetrack - with plex  
stand-off and internal shelf

**CURVE**



OR-TC04  
curve - standard



OR-TC04-P  
curve - with plex stand-off  
and internal shelf



OR-P05-P  
square - shown  
with optional plex

**CIRCLE**



OR-P01  
circle - standard

**TEARDROP**



OR-P02  
teardrop - standard

**EYE**



OR-P03  
eye - standard

**RACETRACK**



OR-P04  
racetrack - standard

**SQUARE**



OR-P05  
square - standard

## ORBITAL TRUSS ACCESSORIES

### LAMINATE TABLETOPS

NATURAL



OR-TBL-WD

MAHOGANY



OR-TBL-DWD

SILVER



OR-TBL-S

BLACK



OR-TBL-B



right facing: OR-TBL2-R-WD  
left facing: OR-TBL-L-WD



right facing: OR-TBL2-R-DWD  
left facing: OR-TBL2-L-DWD



right facing: OR-TBL2-R-S  
left facing: OR-TBL2-L-S



right facing: OR-TBL2-R-B  
left facing: OR-TBL2-L-B

### OPTI MOUNT

OPTI-MOUNT 1



OR-LCD1-B  
13" - 27" LCD  
max weight = 50 lbs

OPTI-MOUNT 2



OR-LCD2-B  
26" - 42" LCD  
max weight = 80 lbs

OPTI-MOUNT 3



OR-LCD3-B  
30" - 50" LCD  
max weight = 130 lbs

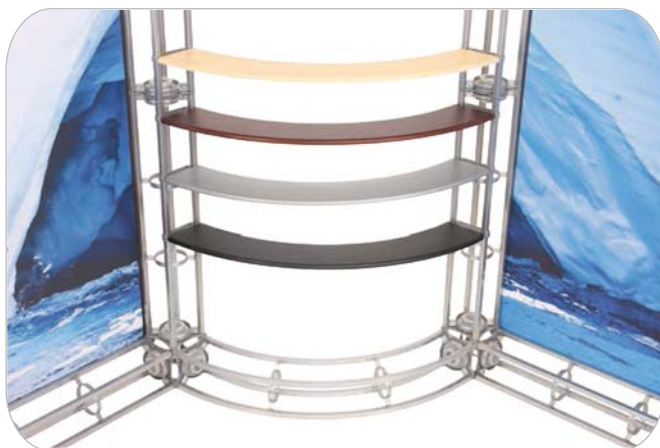

### INTERNAL SHELVING

- available in all 4 finishes (light wood, mahogany, silver & black)
- 24" straight span, 36" straight span, and 46" straight span shelves available
- 45° curved and 90° curved shelves (shown above)



### LIT RACK OR-STG



- 10 pocket clamp on literature rack
- note: rack may not fit into the standard kit packaging solution/molded case



NEW



LIFE TIME

# LINEAR TABLETOP KITS

Linear Table Top Kits provide modern and dynamic flare to your marketing message. The SEG fabric graphics and extrusion-based displays are simple, lightweight and take minutes to assemble. Units come in a sturdy case. Customized units also available.

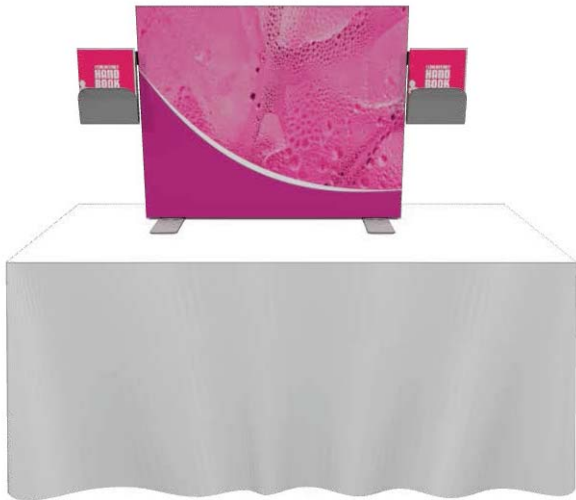

LN-K-TT-01  
57" w x 31.5" h x 17.72" d



LN-K-TT-02  
61.5" w x 31.5" h x 17.72" d

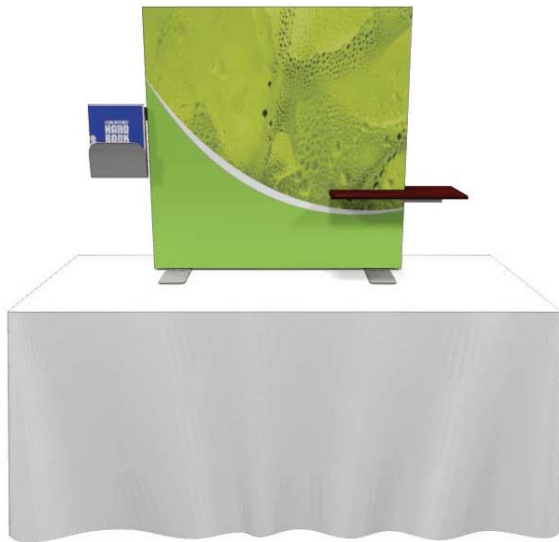

LN-K-TT-03  
53.93" w x 39.37" h x 17.72" d



LN-K-TT-04  
96" w x 39.37" h x 17.72" d



The **NEW** Linear Tabletop kits come with easy-to-apply SEG fabric graphics as well as multiple accessories.



each unit comes in a OCS sturdy case

# LINEAR STANDARD

Linear Standard Kits provide a modern, slick and stylish appearance. The extrusion based exhibits feature **NEW velcro-applied fabric graphics.** Headers and wings available in UV printed graphics or frosted plex. Kits come with two lights and ship in durable storage cases. Options include LCD monitor mounts, tables, counters, literature pockets and larger freight cases. Customized units also available.



Linear counter tops are available in your choice of four thermoform finishes



## LINEAR COUNTER

LN-TBL-SA-RCT

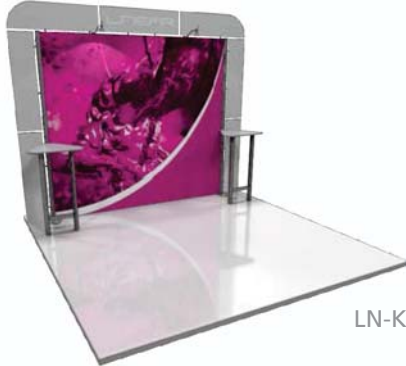

LN-K-3P-01

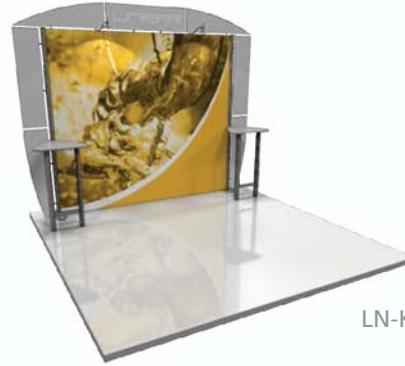

LN-K-3P-02

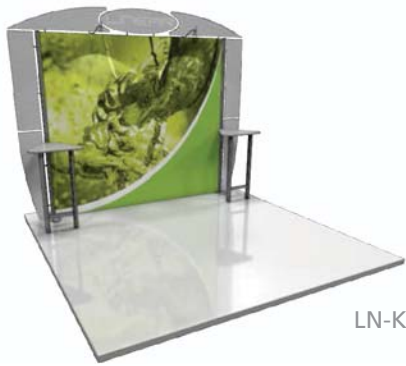

LN-K-3P-03

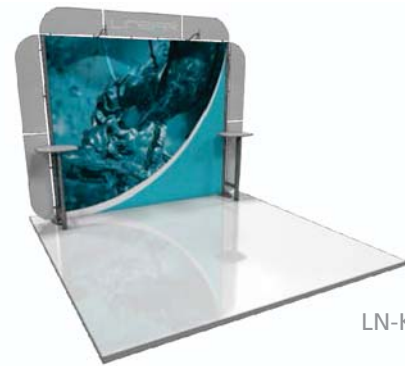

LN-K-3P-05

10'

20'



LN-K-3P-12

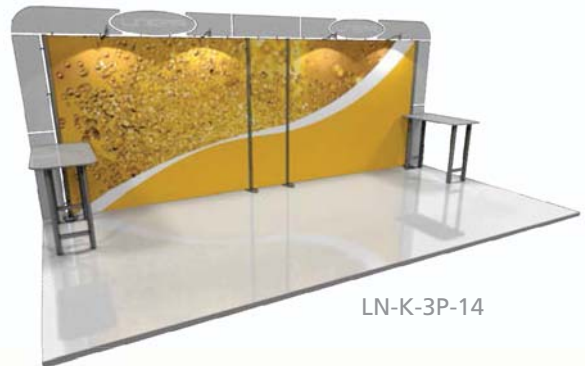

LN-K-3P-14

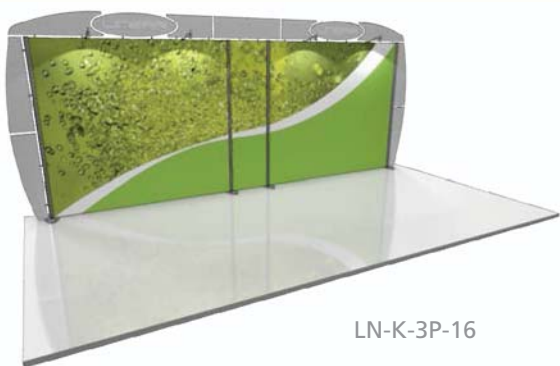

LN-K-3P-16

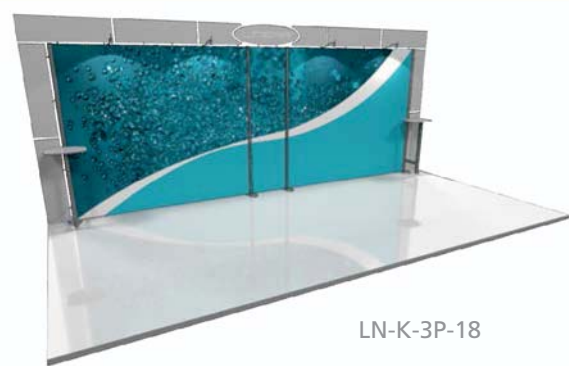

LN-K-3P-18



OCH



## LINEAR PRO

Linear Pro Kits provide a modern, slick and stylish appearance. The extrusion based exhibits feature **NEW velcro-applied fabric graphics.** Headers and wings available in UV printed graphics or frosted plex. Kits come with two lights and ship in durable storage cases. Options include LCD monitor mounts, tables, counters, literature pockets and larger freight cases. Customized units also available.



LN-K-3P-22

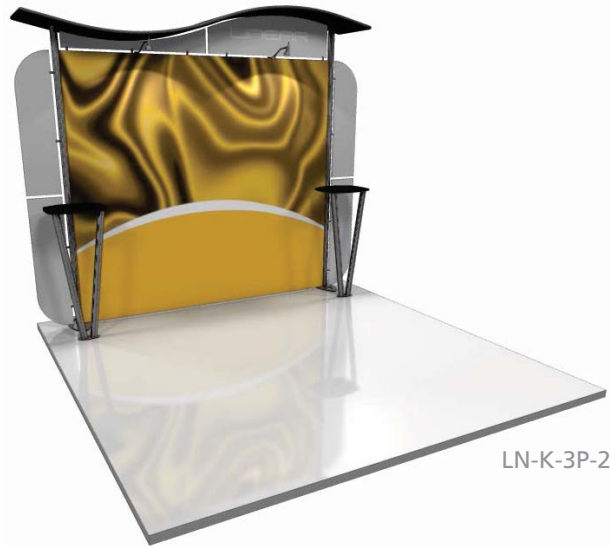

LN-K-3P-25

10'

20'

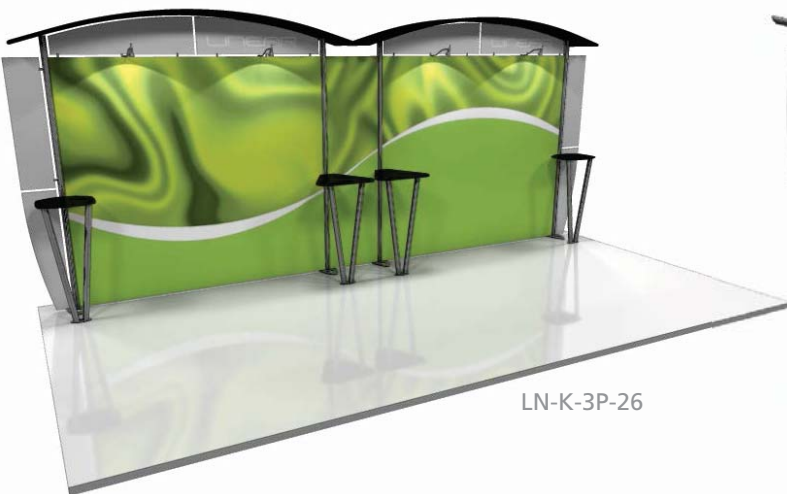

LN-K-3P-26

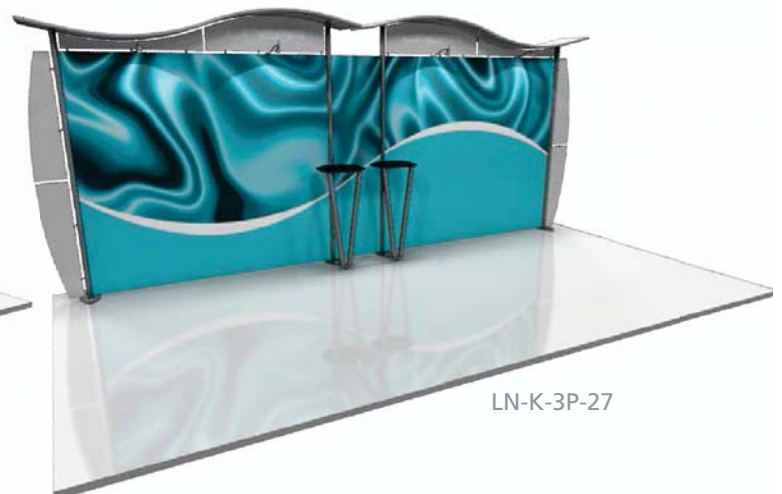

LN-K-3P-27

# LINEAR BOLD

Linear Bold Kits command attention with a heavy-duty aluminum structure and functional, yet stylish features. These hybrid modular displays feature center panel, side and accent headers, tables and lights and ship in durable storage cases. Options include LCD monitor mounts, tables, counters, literature pockets and larger freight cases. Customized units also available.



Linear counter tops are available in your choice of four thermoform finishes

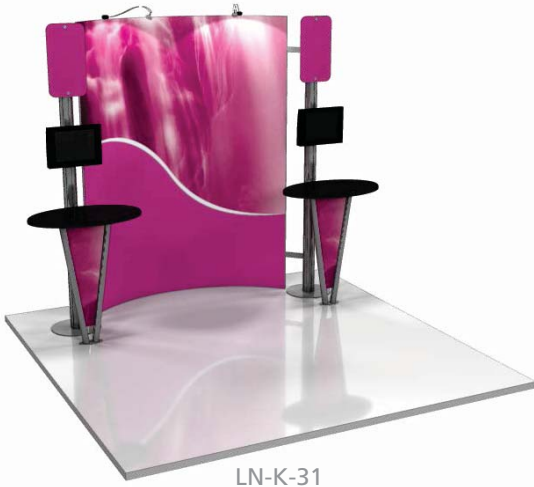

LN-K-31



LN-K-37

10'

20'

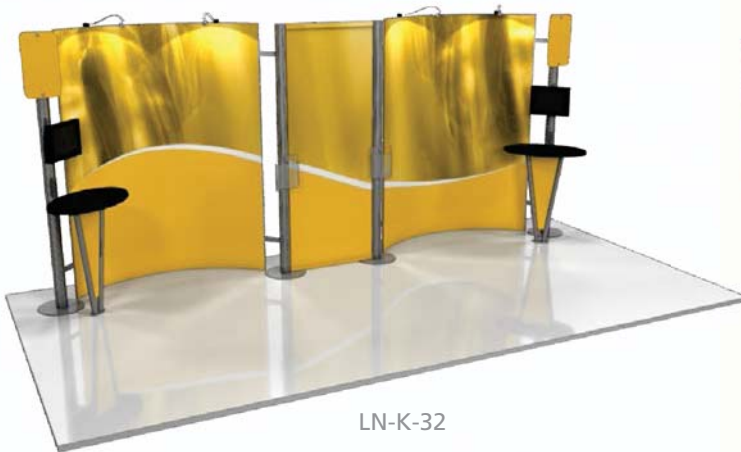

LN-K-32



LN-K-38

## LINEAR ACCESSORIES



Literature Pocket LN112



Monitor Bracket 1 LN-LCD1-B  
13" - 27" LCD  
max weight = 50 lbs



Monitor Bracket 2 LN-LCD2-B  
26" - 42" LCD  
max weight = 80 lbs



Linear counter bases are available in your choice of four laminate options



dove gray black designer white fusion maple

## LINEAR BOLD COUNTERS

Dress up your space with sophisticated and functional counters. Counter tops are available in four thermoform finishes – silver, black, mahogany and natural. Printed graphic panels are available in four laminate colors – dove gray, designer white, black, and fusion maple. Custom counter top colors and graphic colors are available.

LINEAR BOLD COUNTERS



LN-CU-01



LN-CU-02



LN-CU-03



LN-CU-05



LN-CU-06



LN-CU-07



LN-CU-08

# LINEAR KIOSKS



Linear Kiosks provide unique design elements for a custom look. Aluminum construction coupled with rigid graphic infill panels make these kiosks durable and long lasting.

each Linear kiosk comes with an OCH2 case



LINEAR KIOSKS



**LINEAR KIOSK 01**  
LN-K-01

- 54.4" w x 99" h x 23.25" d
- monitor mount
- fabric canopy
- approximate weight: 125 lbs



**LINEAR KIOSK 02**  
LN-K-02

- 47.25" w x 96.85" h x 23.25" d
- monitor mount
- fabric canopy
- approximate weight: 130 lbs



**LINEAR KIOSK 03**  
LN-K-03

- 47.33" w x 96.85" h x 23.25" d
- fabric canopy
- approximate weight: 115 lbs



**LINEAR KIOSK 04**  
LN-K-04

- 63" w x 96.85" h x 30" d
- 50 watt spotlight
- approximate weight: 90 lbs

Linear kiosk counter tops are available in your choice of four thermoform finishes



silver black mahogany natural



## LINEAR KIOSKS

Linear Monitor Kiosks add function and flare to any space. Extrusion-based construction coupled with your choice of rigid graphic infill panels or frosted plex panels make these kiosks sturdy and versatile.



**LINEAR KIOSK 05**  
LN-K-05

- 25.38" w x 72.25" h x 18.5" d
- monitor mount
- approximate weight: 30 lbs



**LINEAR KIOSK 06**  
LN-K-06

- 25.38" w x 72.25" h x 18.5" d
- monitor mount
- approximate weight: 27 lbs



**LINEAR KIOSK 07**  
LN-K-07

- 24" w x 86" h x 21" d
- monitor mount
- approximate weight: 49 lbs



**LINEAR KIOSK 08**  
LN-K-08

- 23.5" w x 86" h x 17.75" d
- monitor mount
- approximate weight: 46 lbs

## LINEAR COUNTER

LN-TBL-SA-RCT

- coordinates with the Linear hybrid modular display line
- 3 graphic panels available to display your custom graphics
- quick & easy to assemble, tool included
- fits in an OCH shipping and transport case
- aluminum design is sturdy and stable



## HOPUP COUNTER

HOP-CT-S

- collapsible display counter
- very portable & lightweight
- includes black internal shelf
- hinged top available in all four laminate finishes



counter tops are available in your choice of finishes



## CAMPAIGN

CP-B2

- quick assembly
- strong & easy to clean plastic parts



## V-CLASS COUNTER

- your choice of four standard patterns, custom graphic option also available
- contoured design creates a refined, substantial look
- quick & simple assembly
- wire management option available
- comes with an OCH shipping & transport case



repositional shelves adjust to your storage needs

sides are available in your choice of printed patterns

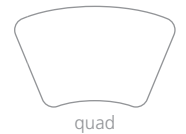
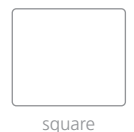
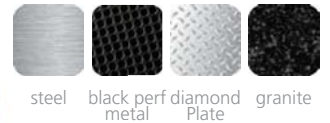

counter stretch skirts are available in the following colors



amethyst ruby sapphire emerald silver jet



## SYMPHONY COUNTER

Symphony counters unique, sleek design lends an attractive element to your tradeshow or P.O.P. display. These counters are quick to set-up, with easy assembly. The modern colors draw attention to your booth and are a perfect complement to any display.

COUNTERS



Oval  
SYM-OV



Quad  
SYM-QD



Rectangle  
SYM-RCT



Bullet  
SYM-BLLT



Oval Grand  
SYM-OV-GRND



Quad Grand  
SYM-QD-GRND



Oval Double Grand  
SYM-OV-DBL-GRND



3 Quad Kit  
SYM-QD-3



Corner Kit  
SYM-CRNR

**BREEZE**



BREZ-1-S: 8.375" w x 13" h  
BREZ-2-S: 11" w x 17" h

- retractable tabletop stand
- ideal for custom calendars & other promotional banners



**VORT-X MINI**



red: VTX-MC  
blue: VTX-MC-BL

- quick & simple to assemble
- ideal for retail/P.O.P. use
- sold in packs of 2
- visual area = 12" w x 16.5" h

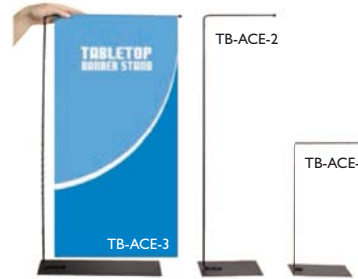

**TABLE ACE**



TB-ACE-1: 6" w x 12" h  
TB-ACE-2: 6" w x 24" h  
TB-ACE-3: 12" w x 24" h

- mini tabletop banner stands
- sold in packs of 3
- black only



**L-MINI**



LMINI

- standard height = 26.875" h
- tabletop tension banner stand
- adhesive rail
- anodized silver finish



**APEX**



APEX

- double-sided plastic a-frame
- can be printed directly on the plastic for a smooth look
- for indoor or outdoor use



**SYNERGY**



SYN-2-1

- double-sided aluminum a-frame
- snap edges for quick graphic changes
- silver anodized finish



**OASIS**



OASIS

- highly portable
- three arm collapsible bag dispenser
- shiny silver finish



**STEP STOOL**



STEP STOOL

- sturdy EZ FOLDZ step stool
- 300 lb capacity
- folds flat for storage & transport
- red only



**WEDGE**



WED-B

- combine multiple units for longer and taller displays
- graphic size is variable
- black only
- graphics not included



**TOWER**



- quick to set up
- 24" and 33" widths available
- tower height = 72"
- lightbox conversion option
- available in black or silver
- large graphic display area

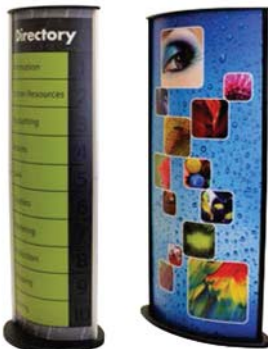

**POSTER SNAPPER**



- snap edges for quick graphic changes
- S-hook or nylon line mount options
- comes in 4 standard lengths
- custom lengths available



**TRAPPA POSTER FRAME**

- black or silver anodized finish w/ precision mitered corners
- spring loaded aluminum extrusions mounted to a high-impact polystyrene backer
- available in a wide range of standard sizes & includes a clear anti-glare lens





**ZEDUP 1**

black: ZD-1-B  
silver: ZD-1-S

- 6 pocket rack
- can be stored or shipped loaded with literature



hard case upgrade:  
black: ZD-1-HC-B  
silver: ZD-1-HC-S



**ZEDUP LITE**

silver: ZD-LITE

- 6 pocket rack
- collapsible
- lightweight version of the ZedUp
- constructed from aluminum & plastic for reduced weight



**INNOVATE**

black: INN-B  
silver: INN-S

- modular design
- 10 pockets
- packs in 3 separate parts for reduced shipping size



**TITAN**

black: TITN-B

- modular design
- heavy duty
- 8 pocket
- packs in 3 separate parts for reduced shipping size



**ILLUSION**

black: IL-1-B  
silver: IL-1-S

- fast-folding cantilever rack
- 4 front facing pockets



**VICTORY**

black: VIC-B  
silver: VIC-S

- slim, modular, snap-together design



**10 UP**

black: 10UP-B

- strong & stable
- 10 pockets
- packs flat



**LR 1 & LR 2**

4 pocket: LR-1  
8 pocket: LR-2

- modular, roll-up mesh design
- holds standard 8.5" w x 11" h literature
- 4 or 8 pocket model
- black with chrome accent



All literature racks come with a five year warranty, a carry bag, and are a eco-friendly choice.

**OCA2**

**OCA2**

- attaches to the OCFM or OCHM
- ideal for lights and accessories
- secure straps help to assure case will remain closed during transport
- interior size: 32.75"l x 13.5"w x 4.25"h
- exterior size: 34"l x 15"w x 7"h
- weight when empty: 8 lbs



**OCB**

**OCB**

- this expandable shipping case fits up to three swivel-foot stands with bags or one premium stand with bag\*
- interior size min/max: min - 28.375"l x 12"w x 3.375"h/ max - 44.25"l x 12"w x 3.375"h
- exterior size min/max: min - 31"l x 17"w x 7"h/ max - 47"l x 17"w x 7"h
- weight when empty: 9 lbs
- \*case does not fit Orchid, Dash, Uno, Spring 5, Contender 48 or banners over 39.37" wide



**OCP**

**OCP**

- light storage in the lid
- secure reinforced straps help to assure case will remain closed during transport
- interior size: 35"l x 21.5"w x 12.25"h
- exterior size: 40"l x 27"w x 18"h
- weight when empty: 21 lbs



**OCP2**

**OCP2**

- premium latches for maximum strength
- hinged lid with internal light storage
- robust, roto-molded plastic
- interior size: 22.5"w x 35"h x 13.13"d
- exterior size: 25.88"w x 40.5"h x 18"d
- approximate weight when empty: 100 lbs



**OCP ELITE**

**OCP-ELITE**

- lid can be used as a step stool while assembling displays
- access door provides storage when unit is used as a counter
- interior size: 35"l x 21"w x 14.25"h
- exterior size: 39"l x 27"w x 18"h
- weight when empty: 31 lbs



**OC-HOP**

**OC-HOP**

- ideal for Hopup backwall displays (fits up to 3x3 hopup)
- built-in handle and wheels for easy transport
- interior size: 34"l x 14"w x 14"h
- exterior size: 36"l x 18"w x 18"h
- weight when empty: 17 lbs



**OCH**

**OCH**

- blow molded case for exhibits, graphics & accessories
- secure reinforced straps help to assure case will remain closed during transport
- strong yet lightweight
- interior size: 47.25"l x 23.75"w x 8"h
- exterior size: 50"l x 29"w x 12"h
- weight when empty: 22 lbs



**OCH2**

**OCH2**

- heavy-duty shipping and storage case
- ideal for Linear hybrid displays
- secure reinforced straps help to assure case will remain closed during transport
- interior size: 48.25"l x 24"w x 14"h
- exterior size: 52"l x 30"w x 15"h
- weight when empty: 30 lbs





## OCHM

### OCHM

- interlocking surface to enable two cases to be transported together
- maximum case depth = 8" allowing up to 8 flat panels per case
- interior size: 36.5"l x 23.75"w x 9"h
- exterior size: 38"l x 28"w x 13"h
- weight when empty: 20 lbs



## OCS AND OCL

small: OCS  
large: OCL

- secure reinforced straps help to assure case will remain closed during transport

### OCL

- interior size: 13.5"l x 13.5"w x 50"h
- exterior size: 19"l x 19"w x 56"h
- weight when empty: 20 lbs

### OCS

- interior size: 13.5"l x 13.5"w x 39.5"h
- exterior size: 19"l x 19"w x 45"h
- weight when empty: 18 lbs



## OCFM

### OCFM

- interlocking surface to enable two cases to be transported together
- maximum case depth= 8" allowing up to 8 flat panels per case
- interior size: 27.25"l x 35.75"w x 9.5"h
- exterior size: 49"l x 39"w x 15"h
- weight when empty: 35 lbs

## OCF

### OCF

- offers the same features and benefits of the OCT in a rectangular shape
- interior size: 47.25"l x 35.75"w x 18"h
- exterior size: 51"l x 38"w x 24"h
- weight when empty: 55 lbs

## OCF2

### OCF2

- molded stackable shipping crate 18" deep
- heavy-duty roller bearing recessed in bridge of case
- holds 18 layers of flat panels in horizontal direction
- interior size: 47.25"l x 47.25"w x 18"h
- exterior size: 51"l x 51"w x 24"h
- weight when empty: 70 lbs



## OCM

### OCM

- black LLDPE Polyethelene case designed for LCD monitors
- built in dry erase board to label contents and location
- fits 37" - 47" screens
- includes 3" casters with rubber wheels
- must be shipped freight
- interior size: 45.5"l x 5"w x 30"h
- exterior size: 54"l x 16"w x 35"h
- weight when empty: 55 lbs



## OCT

### OCT

- designed to handle national & international exhibit freight shipments
- offers maximum protection for your exhibit materials
- interior size: 47.5"w x 34.5"h x 44.25"d
- exterior size: 50"l x 47"w x 43"h
- weight when empty: 138 lbs



All cases come with a one year warranty, are an economic & eco-friendly choice, & made in the USA.



**LUMINA 1**

black: LUM-1-B  
chrome: LUM-1-C

- low voltage 50 watt spotlight & universal fittings kit
- "goose neck" arm
- mounts horizontally
- LED option available



**LUMINA 2**

LUM-2-1

- low voltage 50 watt slender spotlight
- mounts to a vertical pole
- brushed stainless steel finish
- LED option available

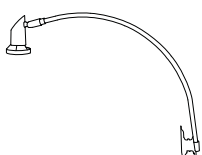

**LUMINA 3**

LUM-3

- low voltage 50 watt spotlight, chrome with a black head & universal fittings kit
- telescopic arm
- extends from 7"-22" long
- LED option available

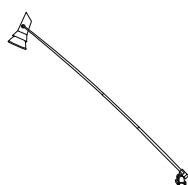

**LUMINA 5**

LUM-5

- low voltage 50 watt spotlight & universal fittings kit
- deluxe chrome head
- telescopic arm
- extends from 7"-22" long
- LED option available

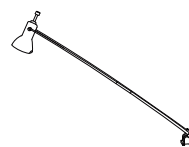

**LUMINA 6**

LUM-6

- low voltage, 50 watt spotlight & universal fittings kit
- stylish curved twin arms
- silk black only
- LED option available

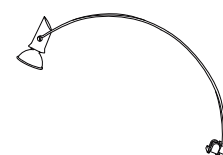

**LUMINA 7**

LUM-7

- incandescent 110 volt fixture
- dovetail mount
- 45 watt incandescent bulb included
- silk black only

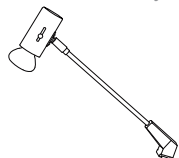

**LUMINA 8**

black: LUM-8-B  
silver: LUM-8-C

- 12 volt spotlight with straight arm & adjustable head
- includes 110 volt UL approved transformer, 50 watt bulb & universal fittings kit
- 17" (431.8 mm) long from end to end
- LED option available

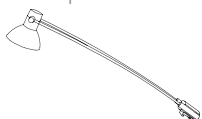

**LUMINA 200**

LUM-200-ORL

- 110 volt ETL approved wall washer floodlight with a straight arm & adjustable head
- light includes 120 watt halogen bulb
- 19.5" (495.3 mm) long from end to end
- silk black finish

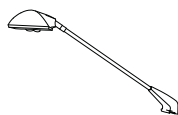

**LUMINA 200 LED**

LUM-LED-ORL-B

- LED version of the Lumina 200 floodlight
- 1400 Ma, 12 VDC
- LED rated for 20,000 continuous hours

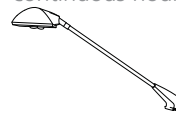

**SPT CASE**

SPT-CASE

- EVA semi-rigid lighting case
- foam-lined padded compartments
- holds two Lumina lights & power supply



**FLD CASE**

FLD-CASE

- EVA semi-rigid lighting case
- foam-lined padded compartments
- stores & transports two lights
- designed for use with Lumina models 1-5



**UNIVERSAL LIGHT CLAMP KIT**

UNI-LT-CLP

- comes standard with the Lumina 1, 3, 4, 5, 6, 8 and allows our lights to fit a majority of banners, truss & panel kits



**LUMINA SPARE BULB KIT**

LUM-BULB

- (2) 50 watt low voltage spare bulbs in a padded, protective EVA formed case



**LED BULB OPTION**

LUM-LV-LED-BLB16

- a green solution for Lumina 1, 2, 3, 4, 5, 6, 8
- 50 watt LED bulb



wayfinding signage solutions available at:

[www.SIGNMAKERS-HANDBOOK.com](http://www.SIGNMAKERS-HANDBOOK.com)

featuring a wide range of configurations for a consistent look throughout your building

**INFO CENTERS**  
**TRIANGULAR SIGNS**  
**DESK FRAMES**  
**SUSPENDED SIGNS**

**FREE STANDING PYLONS**  
**WALL-FRAMES**  
**PROJECTING SIGNS**  
**DIRECTORIES**



user-friendly, versatile, affordable solutions | front-loading design for easy graphic change

**CONTACT US FOR OPTIONS, SPECS & DIMENSIONS**



BROUGHT TO YOU BY:

[www.exhibitors-handbook.com](http://www.exhibitors-handbook.com)

**America's  
Favorite  
Tradeshow  
Supplier**